



Translation of the original Operating Manual

Hot melt adhesive tank system

**HB 5010**

**General Security advice** 1

**Operating Instructions  
HB 5010 (Basic Unit)** 2

**Operating Instructions  
Heatable Hose** 3

**Operating Instructions  
Manual Application Unit** 4

**Declaration of Conformity** 5

**Spare Parts Lists** 6

**Maintenance Plan** 7

# **BÜHNEN**

**KLEBESYSTEME**

BÜHNEN GmbH & Co. KG  
Hinterm Sielhof 25  
28277 Bremen • Germany  
Phone: +49 (0) 421 51 20 - 125  
Fax: +49 (0) 421 51 20 - 260  
kleben@buehnen.de  
www.buehnen.de

Translation of the original Operating Manual

Hot melt adhesive tank system

**HB 5010**

## Table of contents

<b>1</b>	<b>Preface “Working safely”</b> .....	<b>3</b>
<b>2</b>	<b>General</b> .....	<b>3</b>
2.1	Operator’s due diligence .....	3
<b>3</b>	<b>Recommended personnel</b> .....	<b>4</b>
3.1	Competent personnel .....	4
3.2	Instructed personnel.....	4
<b>4</b>	<b>Possible hazards</b> .....	<b>4</b>
<b>5</b>	<b>Notes on safe operation</b> .....	<b>5</b>
<b>6</b>	<b>Notes on handling the batteries</b> .....	<b>5</b>
<b>7</b>	<b>Conduct in emergency situations</b> .....	<b>5</b>

## 1 Preface “Working safely”

With the application system, the hot melt material is heated to high temperatures, conveyed to the application unit and discharged under pressure.

This security advice functions as industrial safety and accident prevention. Noncompliance with the security advice can cause burns, injuries, or death by electricity and/or material damage.

Your cooperation is required to protect you and other persons from harm:

- Always work cautiously.
- Always be aware that hazards are usually not obvious.
- Always use the requisite personal protective equipment for your safety at your workplace.

## 2 General

The components of our application systems were designed and manufactured under consideration of threat analysis and harmonized standards.

These components correspond to the status of technology and permit safe operation.



### **Danger!**

Constructive changes may only be implemented after approval by the manufacturer.

---

### 2.1 Operator’s due diligence

The operation of the application system is only then safe when all requisite measures have been made. It is the due diligence of the operator to initiate these measures and to control its implementation.

Above all, the following must be guaranteed:

- that the application system is only used as intended,
- that the application system may only be operated in a faultless, functioning condition and that the safety lugs are checked regularly,
- that the requisite personal protective equipment is available and is worn,
- that these operating instructions are always available in a legible and complete condition at the site of use,
- that only qualified and authorized personnel – see Chapter 3 – may operate, maintain, and service the application system,
- that all safety and warning notices attached to the application system are not removed and remain legible.

## 3 Recommended personnel

Activity	Requirement
Initial operation	Competent personnel
Facility/Retrofitting	
Operation	Instructed personnel
Electrical maintenance/servicing	Personnel competent in electrics
Mechanical maintenance/servicing	Competent personnel

### 3.1 Competent personnel

Competent persons are those persons having sufficient knowledge in a specific functional area due to their technical training and experience, and who are familiar with the relevant industrial safety and accident prevention provisions as well as the generally acknowledged rules of technology.

### 3.2 Instructed personnel

Instructed personnel are those persons having been instructed about the tasks assigned to them and about the possible dangers due to improper conduct by a competent person who also trains them, as required, in how to use the necessary safety equipment and safety measures.

## 4 Possible hazards



### Danger of burns!

Due to hot metal parts, hot melt material, and hot melt material vapors.

Therefore, always wear heat protection gloves.

Only operate the unit with complete protective covers.

### Remark

Heat protection gloves are special gloves that protect the hands from being damaged by external influences of the thermal type, and especially from contact heat and radiated heat.



### Irritation of mucous membranes!

Hot melt adhesives give off vapors that can have an annoying odorous effect. Therefore, make sure you provide for adequate ventilation. Observe the processing bulletin and the safety data sheet of the hot melt material.

In individual cases, improper processing can cause irritations of the mucous membranes. Consult your doctor immediately!

### 5 **Notes on safe operation**

- Only operate the application system with complete protective covers, closed hoods and faultless safety systems.
- Before starting production, check the application system for signs of visible damage and for faultless condition.
- Never point the application unit towards yourself or at other persons.
- Protect the application system from moisture and wetness.
- Observe the processing bulletin of the hot melt material.
- Always break the power feed (power supply during
  - Maintenance and service works
  - Defective and/or improperly functioning application system.

### 6 **Notes on handling the batteries**

The HB 5010 tank system control unit has a lithium battery. Please note the following safety notes when handling this battery:

- Never cause the battery to short circuit (danger of explosion).
- The battery may not be opened nor dismantled.
- The battery may not be overheated or be subjected to open fire.
- Never clean the battery with water or aggressive liquids.
- Never use leaky or damaged batteries.
- Collect and dispose of used batteries in a proper manner to protect the environment.

### 7 **Conduct in emergency situations**

1. Immediately turn off the main switch.
2. Disconnect the power plug immediately.
3. Only put the unit back into operation after the emergency situation has been eliminated.



BÜHNEN GmbH & Co. KG  
Hinterm Sielhof 25  
28277 Bremen • Germany  
Phone: +49 (0) 421 51 20 - 125  
Fax: +49 (0) 421 51 20 - 260  
kleben@buehnen.de  
www.buehnen.de





Translation of the original Operating Manual

Hot melt adhesive tank system

**HB 5010**



<b>1</b>	<b>Special security advice.....</b>	<b>5</b>
1.1	Possible dangers.....	5
1.2	Intended use .....	5
<b>2</b>	<b>Technical data.....</b>	<b>7</b>
2.1	Product identification.....	7
<b>3</b>	<b>Overview of HB 5010.....</b>	<b>9</b>
3.1	Construction .....	9
3.2	Function .....	10
3.3	Operating and display elements.....	11
3.3.1	Main switch.....	12
3.3.2	Display.....	12
3.3.3	Keypad .....	12
<b>4</b>	<b>Installation / Initial operation .....</b>	<b>15</b>
4.1	Set-up / Installation .....	15
4.1.1	Electrical connection .....	15
4.1.2	Mechanical connection (hoses) .....	15
4.2	First commissioning .....	16
<b>5</b>	<b>Operation .....</b>	<b>17</b>
5.1	Filling the hot melt adhesive.....	17
5.2	Daily turning on .....	17
5.3	Standby operation .....	18
5.4	Turning off .....	18
5.4.1	Turning off in time-controlled operation .....	18
5.4.2	Turning off in manually-controlled operation .....	19
5.4.3	Turning off in emergencies .....	19
<b>6</b>	<b>Programming.....</b>	<b>21</b>
6.1	Introduction .....	21
6.2	Navigation .....	22
6.3	Menu description.....	23
6.3.1	Level 1 menu items .....	23
6.3.1.1	Individual shutdown .....	23
6.3.1.2	Operating mode .....	23
6.3.1.3	Language .....	23
6.3.1.4	Password .....	24
6.3.2	Level 2 menu items .....	24
6.3.2.1	Temperatures .....	24
6.3.2.2	Time operation .....	25
6.3.2.3	Date/Time .....	25
6.3.2.4	System.....	26
6.3.2.5	Load factory settings.....	26
6.3.3	Level 3 menu items .....	27
6.3.3.1	Limit values .....	27
6.3.3.2	Waiting time .....	28
6.3.3.3	Pump settings .....	28
6.3.3.4	Celsius / Fahrenheit.....	30
6.3.3.5	Sensor selection .....	30

# Table of Contents

6.3.3.6	Control parameters .....	30
6.3.3.7	Optimization .....	31
<b>7</b>	<b>Set-up / Retrofit .....</b>	<b>33</b>
7.1	Removing / Replacing the Housing .....	33
7.2	Setting the pump pressure .....	34
7.3	Changing the hot melt material .....	36
7.4	Releasing system pressure .....	36
7.5	Dismantling a heated hose .....	36
<b>8</b>	<b>Maintenance / Servicing .....</b>	<b>37</b>
8.1	Maintenance intervals .....	37
8.2	Cleaning .....	37
8.3	Replacing the back-up battery .....	38
8.4	Inspection and replacement of fuses .....	40
<b>9</b>	<b>What happens if.....</b>	<b>42</b>
9.1	General errors .....	42
9.2	Error messages in the display .....	43
<b>10</b>	<b>Accessories .....</b>	<b>45</b>
10.1	Spray-air adapter kit.....	45
10.1.1	Overview .....	45
10.1.2	Assembly .....	46
10.1.3	Setting the optimum working pressure .....	46
10.1.4	Maintenance.....	47
<b>11</b>	<b>Repairs .....</b>	<b>48</b>
<b>12</b>	<b>Warranty .....</b>	<b>48</b>
<b>13</b>	<b>Disposal .....</b>	<b>48</b>

## 1 Special security advice

---



### Info

Please also note the “General Warning Notes” in Part 1 of this manual.

---

### 1.1 Possible dangers

---



#### Danger of burns

due to hot metal parts, hot melt material, and hot melt material vapors.

Therefore, always wear heat protection gloves.

Only operate the unit with complete protective covers.

---

### 1.2 Intended use

The HB 5010 tank system is used to melt and convey hot melt materials.

Application of the hot melt materials is done using one or two heated hoses with one manual application unit each.

The tank system is designed for commercial or industrial use.

Only hot melt materials that have been checked and released by the manufacturer may be processed in the HB 5010 tank system. Reactive hot melt adhesives, such as PU (polyurethane) hot melt adhesives may not be processed.



## 2 Technical data

Designation	HB 5010
Dimensions (W x D x H)	720 mm x 360 mm x 360 mm
Weight	35 kg
Power supply	230 VAC/50 Hz
Max. power consumption	2,900 W
Max. current consumption	13.5 A
Type of protection	IP32
Class of protection	1
Temperature control	Electronic 6-channel temperature controller expandable to 10 channels
Heating capacity of tank	1,260 W
Permitted connected load per hose	1,440 W
Permitted connected load for manual application unit	400 W
Working temperature	135...210 °C
Temperature sensor	Pt 100, alternatively Ni 120 for hose and manual application unit
Hose connections	2
Overtemperature protection	Yes, limited to 260 °C
Permitted ambient temperature	0...40 °C
Melting capacity	4.5 kg/h
Warming-up period	approx. 30 minutes
Pump system	Gear wheel pump
Pump capacity	26 kg/h
Drive	Geared motor
Rotational speed of pump	65 r.p.m.
Bypass valve setting	35 bar; max. 55 bar
Usable tank volume	4.5 liters
Noise emission	72 dbA

### 2.1 Product identification

These operating instructions apply to all HB 5010 basic units with the following illustrated type plate.



Figure 2.1/1: Type plate on unit (example)

Two type plates are attached to the HB 5010 basic unit:

- on the left narrow side of the housing
- on the inside of the unit on the left side of the housing of the control electronics (see following figure)

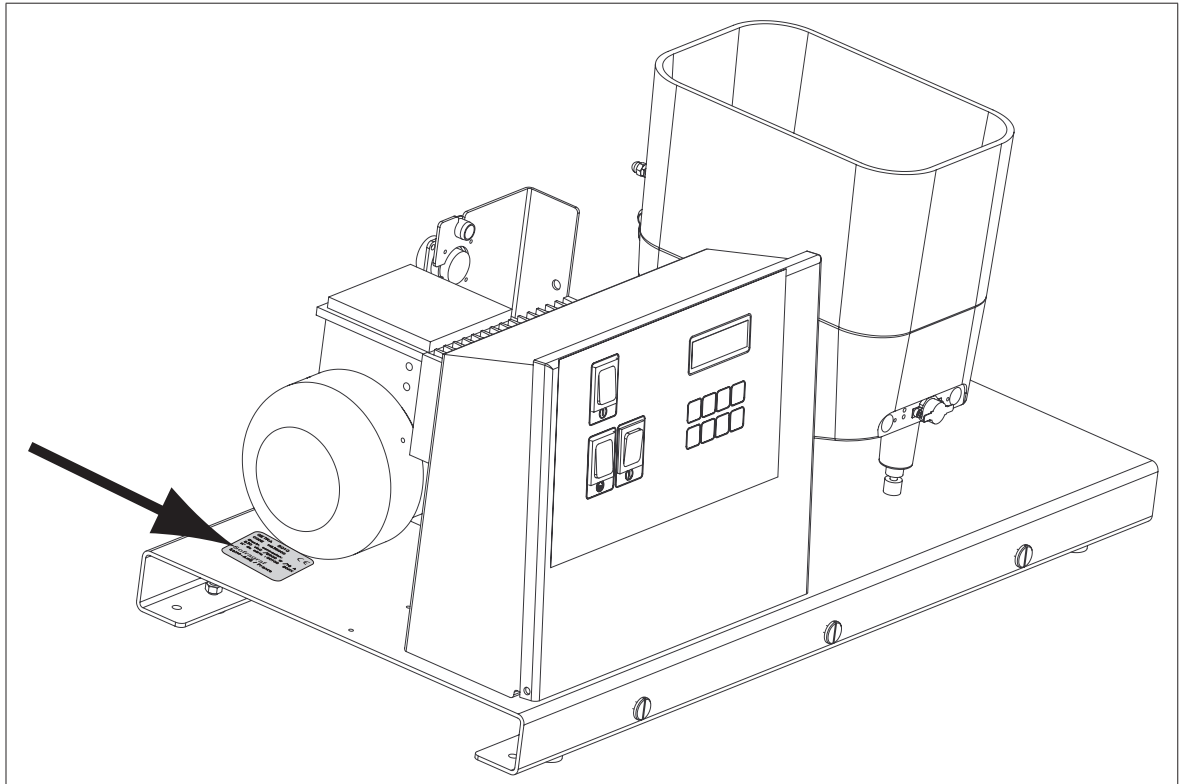

Figure 2.1/2: Location of type plate on the inside of the unit



**3 Overview of HB 5010**  
**3.1 Construction**

The following figures show the HB 5010 tank system and its components with removed housing:

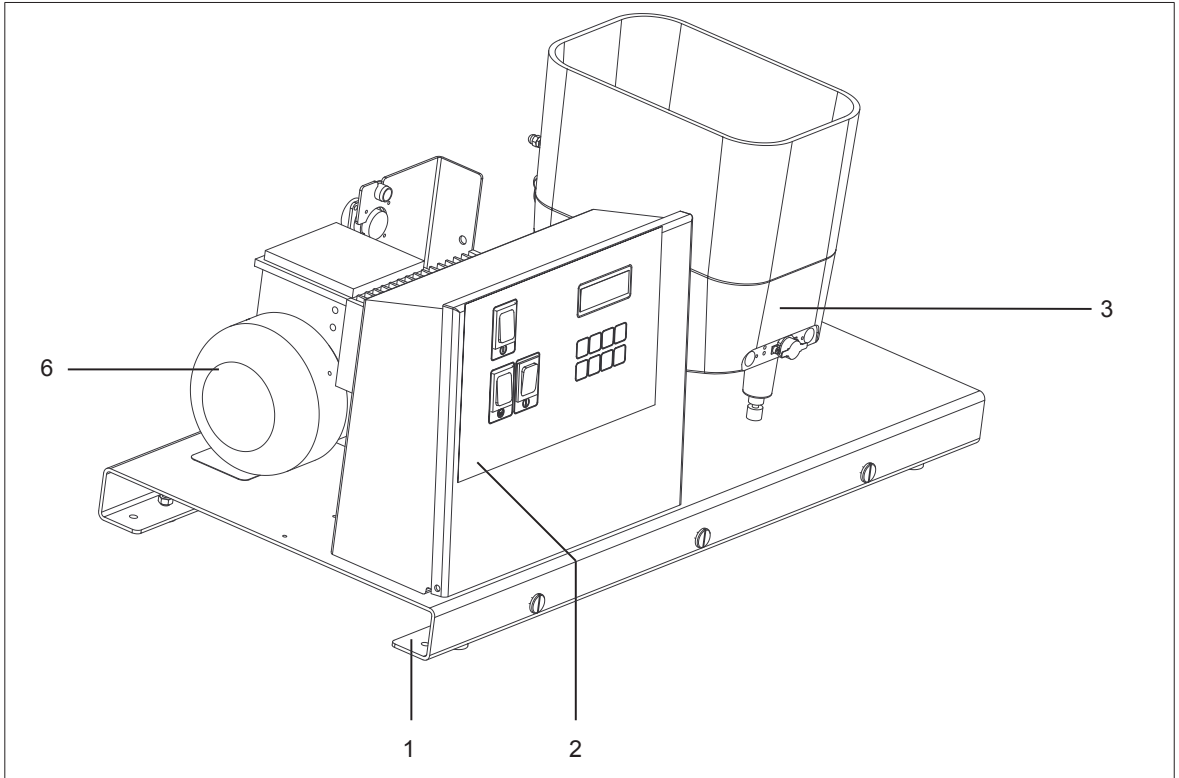

Figure 3.1/1: Front view

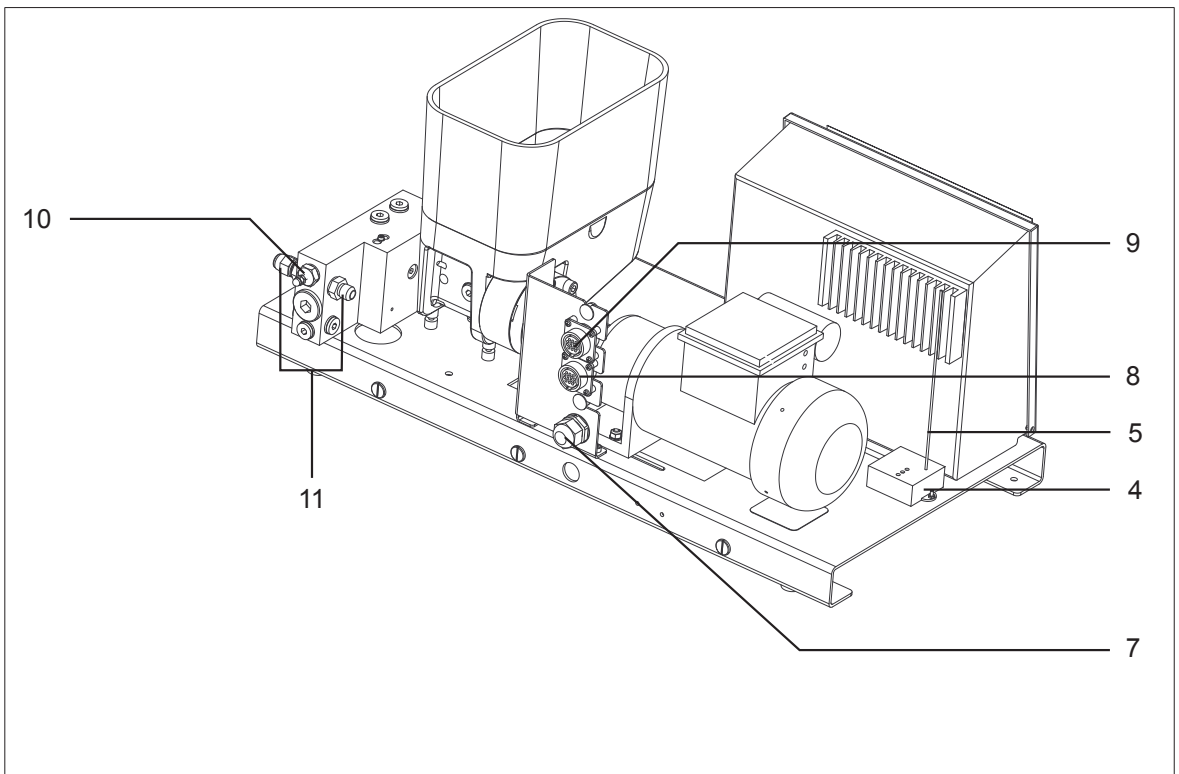

Figure 3.1/2: Back view

Lfd. Nr.	Bezeichnung
1	Console
2	Switch cabinet with temperature control and pump control
3	Hot melt adhesive tank with heat insulation
4	Receiver for remote control
5	Receiving aerial for remote control
6	Pump motor
7	Power cable
8	Electrical connection for Hose 2
9	Electrical connection for Hose 1
10	Adjusting screw for pump pressure
11	Connections for hoses (adhesive)

## 3.2 Function

The HB 5010 hot melt adhesive application system is used for melting and applying adhesives (intended use).

All components are mounted onto a sturdy console made of sheet steel. The hot melt adhesive is filled into the tank (3) in solid form and then melted. The temperature of the hot melt adhesive in the tank can be pre-set using the control unit. The temperatures for the hoses and manual application units can also be pre-set individually.

The control electronics keep the temperatures of all components at the selected values. If the control electronics become defective, an integrated temperature sensor switches off the system to prevent overheating.

The tank system can be utilized in two operating modes:

- **Time-controlled operation**

The main switch remains turned on in this operating mode. Software controls the turning on and off. The turning on and off times can be programmed for each day of the week.

A temperature drop (“standby”) can be programmed for work breaks to avoid the adhesive from oxidizing too quickly. The times for standby operation can be individually programmed for each day of the week. The “time-controlled” operating mode is optimal for regular, predictable requirements (shift operation).

- **Manually controlled operation**

In the “manually controlled” operating mode, the tank system is turned on and off as required using the main switch. This operating mode is suitable for irregular requirements.

The gear wheel pump conveys the melted adhesive through the hoses (max. of 2) to the manual application units. The gear wheel pump can operate in two modes:

- **Continuous operation**

The gear wheel pump runs continuously. A bypass valve conveys the non-discharged adhesive back into the tank.

- **Requirement-controlled operation**

The gear wheel pump is controlled by the manual application units via wireless remote control. Follow-on time can be programmed at the control unit.

The entire system is a modular construction. All electrical connections are pluggable designs. This guarantees that all components can be exchanged quickly.

All main parameters (temperature, operating conditions) are shown as four-line plain text in the display of the control unit.

The control unit is programmed through menu-driven plain text entries. It is divided into several password-protected levels to prevent faulty operation through non-authorized personnel.

The parameters can be reset to the delivered state at any time.

### 3.3 Operating and display elements

All operating and display elements are combined in the control unit.

A four-line, illuminated display is used to display important process data in normal mode.

In the programming mode, all parameters that can be set with their values are displayed in plain text. A clear menu structure guides the user through the programming mode.

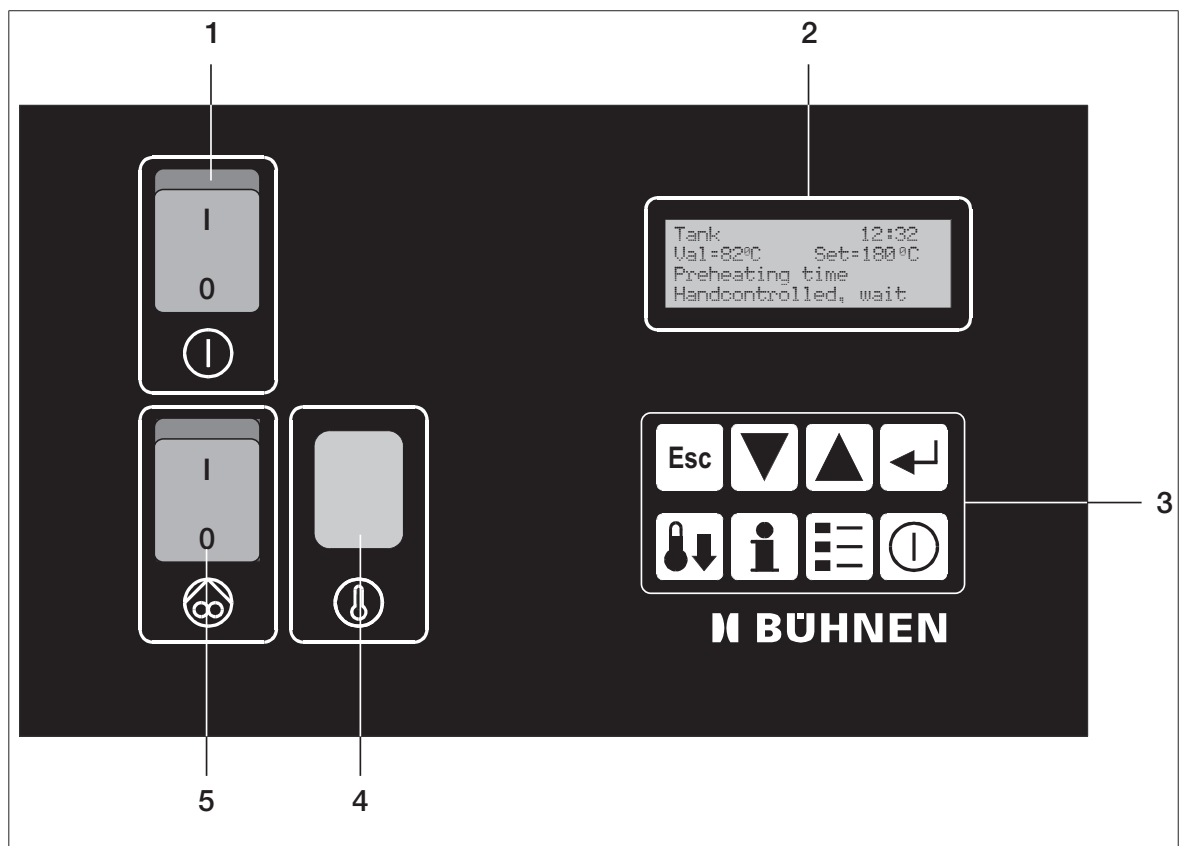

Figure 3.3/1: Operating and display elements of the control unit

Ser. No.	Description
1	Main switch (On/Off)
2	Display, four lines, illuminated
3	Keypad
4	"Temperature reached" control lamp
5	Pump switch

The following chapters describe the function of the individual operating and display elements.

### 3.3.1 Main switch

The entire tank system is turned on and off with the main switch.  
In the disconnected condition, the system is switched completely to zero current.

### 3.3.2 Display

The display shows the current process values in the normal mode:

1. Time
2. Target and actual values of tank, pump, hose, and pistol temperatures.
3. Operating conditions (time-controlled, manually controlled, heating mode on/off, etc.)

The process values of the individual components (tank, pump, Hose 1, Pistol 1, etc.) are displayed in succession. The next display is switched to after approx. 3 seconds.



Figure 3.3.2/1: Display example (normal mode)

### 3.3.3 Keypad

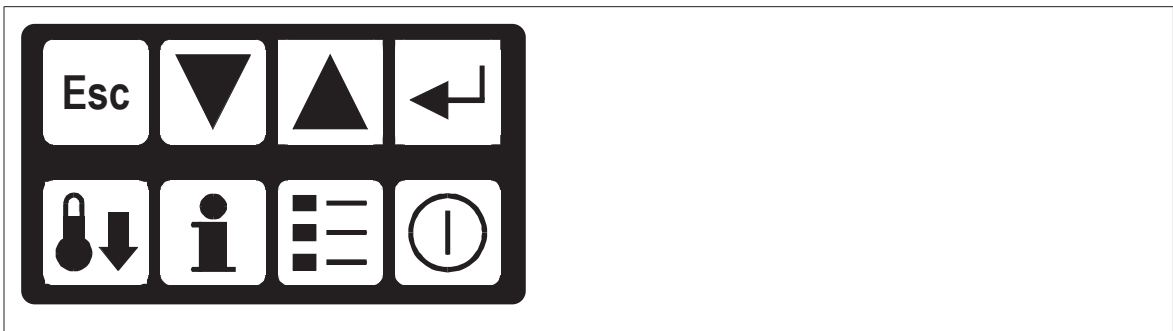

Figure 3.3.3/1: Keypad

The keypad has 8 membrane keys which protects them from environmental effects. All operating and programming entries are made using these keys. The functions of the keys are described individually in the following:



#### Escape (Cancel)

Use this key to exit a menu function. You are taken to the next higher level in the menu structure.



#### Down arrow

This key has 2 functions:

- When maneuvering in the menu structure, the cursor is moved down one line in the display or moved to the next position.
- When entering a value, the current value is decreased.



#### Up arrow

This key has 2 functions:

- When maneuvering in the menu structure, the cursor is moved up one line in the display or moved back one position.
- When entering a value, the current value is increased.



**Enter**

This key confirms the entry of a value or the selection of a menu item (using the up/down arrow).



**Standby**

By pressing this key, the tank system in manual operation is switched to active standby mode. The temperature of the hot melt material is decreased by a previously programmed value (factory setting: 40 °C) in order to protect the hot melt material (e.g. during work breaks). During time mode, the system will switch into manual mode after this key has been pressed.



**Info**

The current actual or target values of all components are displayed when this key is pressed. Use the “Up arrow/Down arrow” keys to switch between the actual and target values. After a time, the display will switch back into normal view.

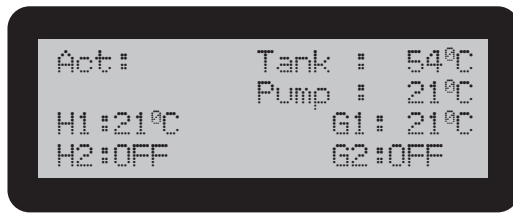

Figure 3.3.2/1: Display after pressing the “Info” key (Example)



**Menu**

The menu key switches the control unit to programming mode. The programming menu is displayed. A blinking spot indicates the position of the cursor. Maneuver within the menu using the “Up/Down arrow,” „Entry,” and „Cancel“ keys.

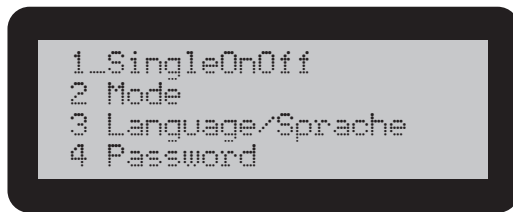

Figure 3.3.2/1: Display after pressing the “Menu” key



**On/Off**

This key turns the tank system on and off (per software).

After turning off with activated timer, the timer remains in operation and will turn on the tank system at the next programmed time.

The following security prompt is displayed first:



Figure 3.3.2/1: Security prompt before turning off

## Overview of HB 5010

Press "Enter" to definitely turn off the system.

Pressing the on/off key again turns the tank system back on.



### Info!

Please note that the tank system will work in the "**manually controlled**" operating mode in any case after being turned on again by the on/off key, i.e. the tank system will not turn off automatically.

To reactivate the limiting timer, the main switch (1) must be turned off briefly and turned back on again.

---

## 4 Installation / Initial operation

### 4.1 Set-up / Installation

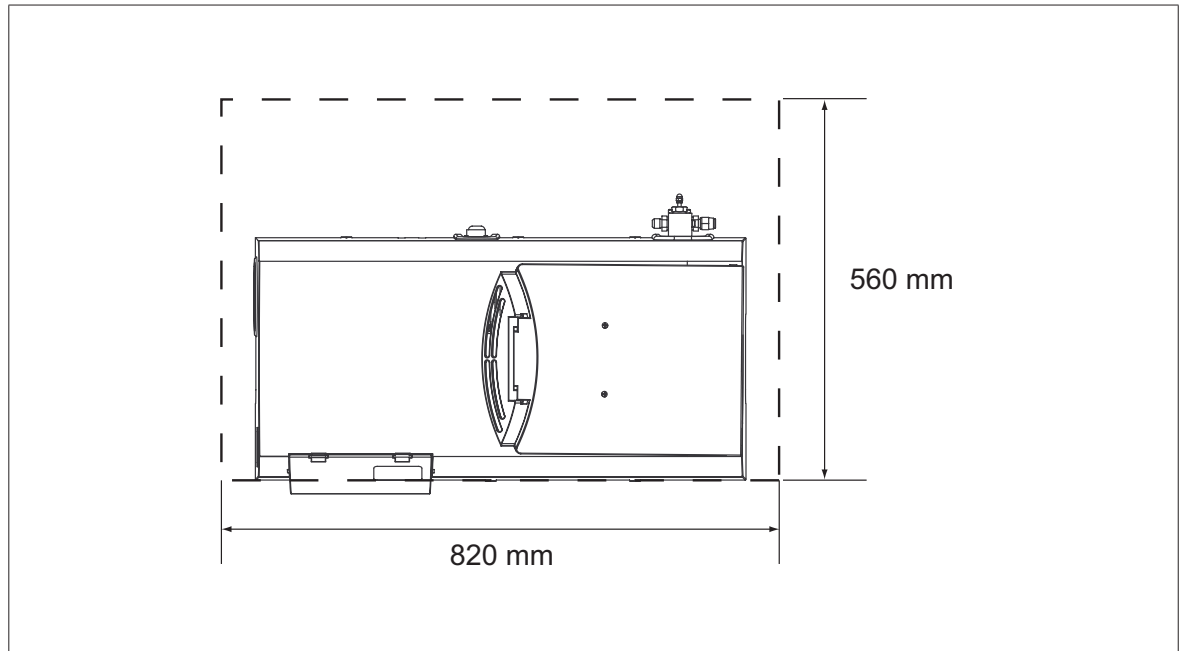

Figure 4.1/1: Required space

After unpacking, place the system on a sturdy work surface that will securely bear the weight of the system (38 kg). Lift the unit only by its frame.

Leave enough room at the sides (about 50 mm all round) to ensure unobstructed air circulation.

Installation space of approx. 200 mm is required at the back to connect the hoses and to set the pump pressure.

Set up the unit in such a way that it is protected from moisture, vibrations, and strong dust accumulation. The permissible ambient temperature is 0...40 °C.

Figure 4.1/1 shows the required space.

#### 4.1.1 Electrical connection

A protective conductor outlet with the following values is required for the electrical connection:

Voltage:	240 V AC
Frequency	50 Hz
Output:	2.9 kVA
Required fuse:	16 A

#### 4.1.2 Mechanical connection (hoses)



##### **Danger of burns!**

When connecting the hoses, it is possible to receive burn injuries at the hose connections.

Therefore, always wear heat protection gloves when doing this work.

##### **Required tool**

- 2 open-end wrenches size 19

To connect a hose, carry out the following work steps:

1. Shut down the tank system.
2. Connect the electrical hose connection with the corresponding connection of the tank

system (see Figure 3.1/2). The following assignment applies: Hose 1 to connection (10), Hose 2 to connection (9).

3. Turn the tank system on. Wait until the hose has reached a temperature of approx. 100 °C. The display at the front of the unit helps to track the temperature.
4. Now screw on the cap nut of the hose by hand onto the corresponding connection of the tank system (see (12) in Figure 3.1/2).
5. Secure the connection at the tank system with an open-end wrench (size 19). Using the other open-end wrench, tighten the cap nut of the hose.
6. If one of the connections will not be used, then it must be securely sealed with a blind plug.

### 4.2 First commissioning

Perform the following work steps for first commissioning:

1. Make sure that the system has been correctly connected to a protective conductor outlet.
2. Make sure that the hose connections, or the blind plug, are screwed securely.
3. Open the tank cover and fill the desired hot melt adhesive into the tank. Fill up the tank up to maximally 25 mm below the upper edge of the tank.
4. Turn on the main switch. The unit will now begin with the warming up procedure. Depending on the working temperature set and the amount of hot melt adhesive filled, the warming up procedure may last up to half an hour. The temperatures of the tank, hose, and manual application unit can be monitored in the display.
5. As soon as the working temperature has been reached, the “Temperature reached” control lamp lights up.
6. Now turn on the pump drive.
7. Hold the nozzle of the manual application unit over a piece of cardboard or similar underlay. Continue activating the trigger until a continuous stream of hot melt adhesive is discharged from the nozzle.
8. After manufacture, the unit was subjected to a function test. Hot melt adhesive was filled during this test, and the residue must be removed before first use. Continue activating the trigger until only the hot melt adhesive that you filled in is discharged from the nozzle.
9. This concludes the first commissioning. The tank system can now be programmed and utilized.





5

**Operation**

5.1

**Filling the hot melt adhesive**

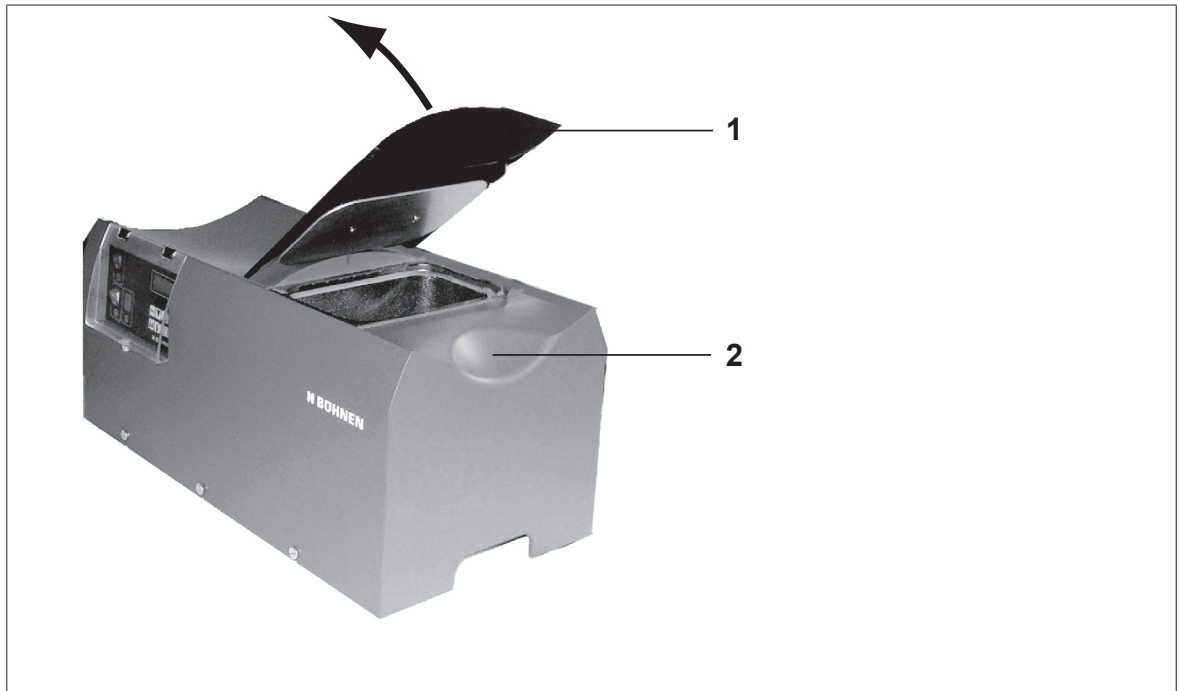

Figure 5.1/1: Opening the tank lid

To fill in the hot melt adhesive, carry out the following work steps:

1. Reach into the recessed grip (2) and swivel the lid (1) towards the direction of the arrow.
2. Make sure that the tank and the hot melt material is free from impurities and foreign objects.  
Impurities and foreign objects in the tank can damage the gear wheel pump or even destroy it, or clog the manual application unit.
3. Carefully fill the hot melt material into the tank. Fill up the tank up to a maximum of 25 mm below the upper edge.  
Since hot melt materials expand during warming, overfilling with hot melt material could cause uncontrolled overflow.
4. Close the tank lid directly after filling is completed.

5.2

**Daily turning on**

In the “time-controlled” operating mode, the main switch remains turned on permanently. Daily turning on and off occurs automatically by the control unit.

In the “manually controlled” operating mode, the tank system is turned on manually. To do so, carry out the following work steps:

1. Make sure there is enough hot melt adhesive in the tank. We recommend refilling when the tank is half full (heater ribbing in tank are visible)
2. Turn on the main switch.
3. Wait until the tank system has reached its operating temperature (or the somewhat lower release temperature). The control lamp (4) “Temperature reached” lights up.
4. Switch in the pump.  
Depending on the selected pump operating mode, the pump will run in continuous mode or is controlled by the trigger of the manual application device.
5. The tank system is now ready for operation.



## 5.3 Standby operation

To protect the hot melt material during temporary work interruptions (e.g. breaks), the tank system can be set into standby operation. The temperature of the hot melt material is decreased by a pre-set value (factory setting: 40 °C).



By pressing the “standby” key, the tank system is set into standby mode. The following security prompt is displayed:

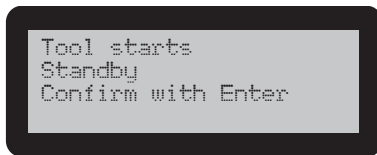
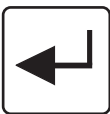

Figure 5.3/1: Security prompt “standby”



Press the “Enter” key

The display now shows the following:

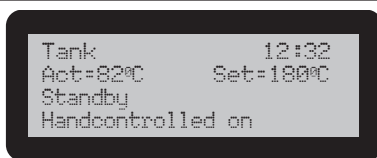

Figure 5.3/2: Display in “standby” mode



By pressing the “standby” key again, the tank system will switch back into normal operation.

The security prompt must be confirmed here again:

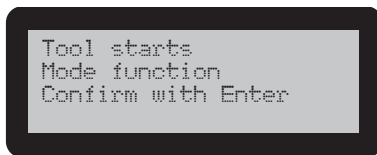

Figure 5.3/3: Security prompt “Reactivate”

## 5.4 Turning off

### 5.4.1 Turning off in time-controlled operation

The main switch remains turned on permanently in “time-controlled” operation. Daily turning on and off occurs automatically by the control unit.

The tank system can also be manually switched off in the “time-controlled” operating mode.



To do so, press the “On/Off” key.

The following security prompt is displayed:



Figure 5.4.1/1: Security prompt “Turn off”



Press the “Enter” key.

All heaters and controllers are switched off. The control lamps of the main and pump switches remain lit; the display extinguishes.

The control unit remains in operation and will turn the tank system back on at the next programmed time.

Pressing the “on/off” key again turns the tank system back on.



### Info!

Please note that the tank system will work in the “manually controlled” operating mode in any case after being turned on again with the on/off key.

After the next automatic turning on by the control unit, the tank system will operate in the “time-controlled” operating mode..

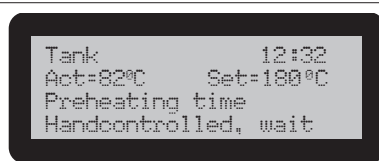

Figure 5.4.1/2: Display after reactivation (Example)

#### 5.4.2 Turning off in manually-controlled operation

To turn off in the “manually controlled” operating mode, carry out the following work steps:

1. Turn off the pump drive with the pump switch.
2. Turn off the main switch.

#### 5.4.3 Turning off in emergencies

If the tank system display unexpected operating behavior or if an emergency occurs, the system must be switched off immediately and switched to zero current. To do so, carry out the following work steps:

1. Turn off the pump drive with the pump switch.
2. Turn off the main switch.
3. Disconnect the power plug.
4. Have a competent electrician check the tank system and repair it if necessary. The tank system may only then be put back into operation.



## 6 Programming

### 6.1 Introduction

The entire HB 5010 tank system programming is done using a clearly structured menu. The required messages and entries are depicted in a four-line display in plain text. Related functions are consolidated in one menu item each and can be quickly accessed.

To prevent faulty operation, the programming has been divided into three levels that are protected by a password in part:

#### Level 1 (User)

The menu items of Level 1 can be accessed without a password. Here

- Individual hoses and manual units (pistols) can be turned on and off
- The operating mode (manual/time-controlled) and the
- Display language can be selected

The default password for Level 2 is: „1234“.

#### Level 2 (Master)

Level 2 is protected by a (freely selectable) password. The following settings can be made here:

- Temperature pre-selection for all components (tank, pump, hoses, manual application units)
- Turning on and off and standby times, individually for each weekday
- System date and time
- General system data (operating hours, software and hardware versions) can be displayed.
- Resetting all settings to factory settings

The password for Level 3 is: „9744“.

#### Level 3 (only for trained Service Personnel)



#### Danger!

The password-protected parameters of Level 3 have a main impact on the operating safety and the operating behavior of the entire tank system. Wrong and/or improper entries can lead to unpredictable operating behavior, damage to the unit or the processed materials. **For the above reason, these parameters may only be changed by especially trained personnel!**

---

Level 3 is protected by a non-changeable password. System-oriented parameters may be set here, such as

- Temperature limit values
- Operating mode of pump
- Temperature unit (Celsius/Fahrenheit)
- Selection of utilized temperature sensors
- Controller parameters

Figure 6.1/1 offers an overview of the menu structure:

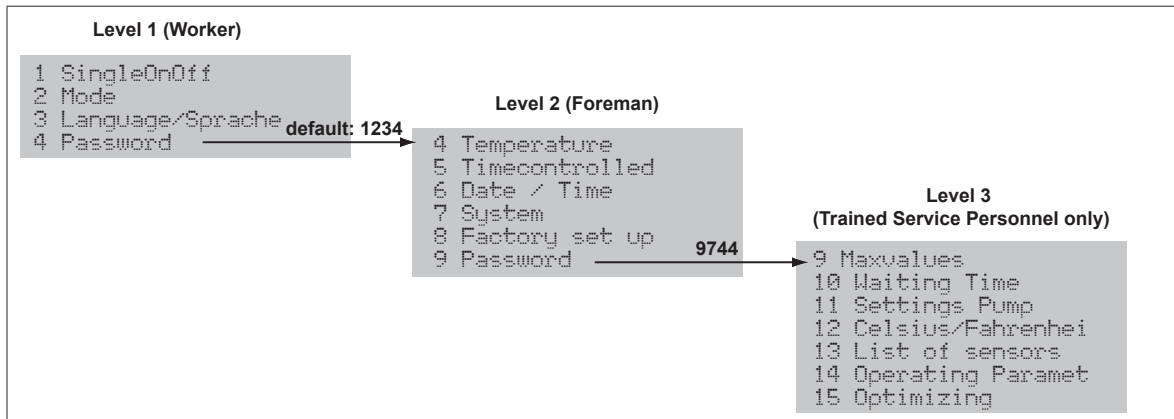

Figure 6.1/1: Overview of menu structure

## 6.2 Navigation

The “up/down arrow,” “enter,” and “ESC” keys are used to navigate in the menu structure (see Chapter 3.3.3).



Press the “Menu” key to switch the tank system to programming mode. The display shows the menu items of Level 1 (see Figure 6.1/1).

Use the “Up/Down Arrow” to select the desired menu item. You can recognize the current menu item by the flashing cursor between the serial number and the associated menu item.



Press “Enter” to confirm your entry.

The selected menu item is displayed.

If this menu item is divided into submenus, you can switch between the submenus with the “Up/Down Arrow.” Use “Enter” again to select the desired submenu. Navigation within the individual parameters occurs in the same manner.

- Select the desired parameter in the list using the “Up/Down Arrow.”
- Press “Enter” to activate the parameter
- Use the “Up/Down Arrow” to set the desired value.
- Press “Enter” to confirm the value.



“Esc” takes you back to the next higher Level in the menu structure.

## 6.3 Menu description

### 6.3.1 Level 1 menu items

#### 6.3.1.1 Individual shutdown

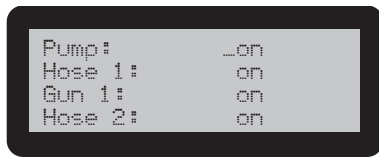

Figure 6.3.1/1: "Individual shutdown"

Not connected or not required components can be individually turned on and off. Shut down components will not be heated.

In normal operation, a component is automatically detected and activated after it has been connected. Dismantling a component is also automatically detected.

If a connection is shut down manually here, then automatic detection and activation/deactivation does not occur.

#### 6.3.1.2 Operating mode



Figure 6.3.1.2/1: "Operating mode"

You can set the operating mode of the tank system here:

- **Time-controlled**

The tank system is automatically turned on and off at previously specified times. (See also Chap. 6.3.2.2 "Time Operation") One standby phase per day (e.g. for breaks) can also be set. The times can be specified individually for each day of the week.

This operating mode is optimal for regularly recurring working times (e.g. shift operation).

- **Manually controlled**

In manually controlled operation, the tank system is manually turned on and off.

#### 6.3.1.3 Language

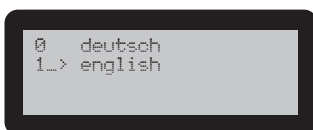

Figure 6.3.1.3/1: „Language“

Select the language of the display in this menu item. German and English are currently available.

## 6.3.1.4 Password



Figure 6.3.1.4/1: "Password"

You can enter the four-digit passwords for Levels 2 and 3 here.

Select each digit with "Up/Down Arrow" and confirm the digit with "Enter."

After entering the Level 2 password, 5 additional menu items can be selected (see Chap. 6.3.2) and after entering the main password (Level 3), all menu items can be selected (see Chap. 6.3.3).

## 6.3.2 Level 2 menu items



### Info!

If the cursor remains on a menu item for a longer period without selecting it, the display will return to normal mode. After activating the menu item (with "Enter"), the selected menu item will remain displayed.

## 6.3.2.1 Temperatures

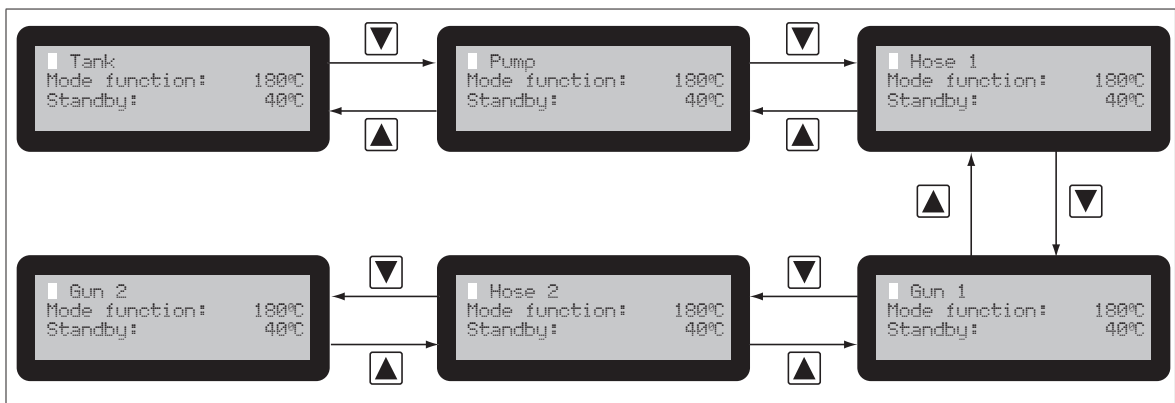

Figure 6.3.2.1/1: "Temperatures"

Temperature values for normal and standby operation are specified for the individual components here:

- Tank
- Pump
- Hose 1
- Pistol 1
- Hose 2
- Pistol 2

A submenu is available for each component (see Figure 6.3.2.1/1). Navigate between the individual submenus with "Up/Down Arrow."



### Info!

Please note that the "standby" temperature value is only a relative value based on the temperature in normal operation. It specifies **by which value** the temperature **will be lowered** in standby operation.



## 6.3.2.2 Time operation

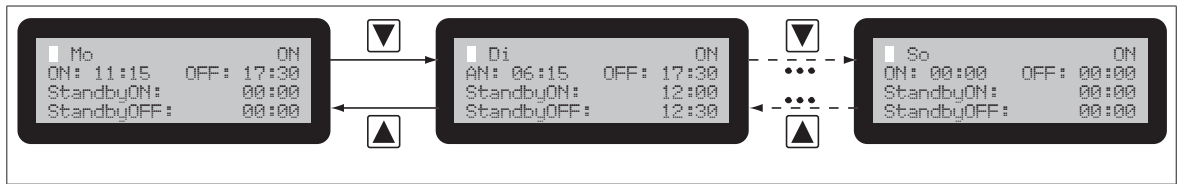

Figure 6.3.2.2/1: "Time operation"

The switching times for the time-controlled operation are specified here for every day of the week:

- Day (ON/OFF)
- Turn on time (ON)
- Turn off time (OFF)
- Begin standby time (Standby ON)
- End standby time (Standby OFF)

A submenu is available for every day of the week (see Figure 6.3.2.2/1). Navigate between the individual submenus with "Up/Down Arrow."

## 6.3.2.3 Date/Time



Figure 6.3.2.3/1: "Date/Time"

The tank system has a battery-supported realtime clock. The date, time, and display format of the date is entered in this menu item.

Three different date formats can be selected (example: July 14, 2005)

- DD-MM-YY (display: 14-07-05)
- YY-MM-DD (display: 05-07-14)
- MM-DD-YY (display: 07-14-05)



### Info!

Self-acting resetting of system time/date or the error message depicted below indicate a drained battery. In this case, replace the battery immediately (see Chap. 8.3) to ensure the faultless function of the time control.

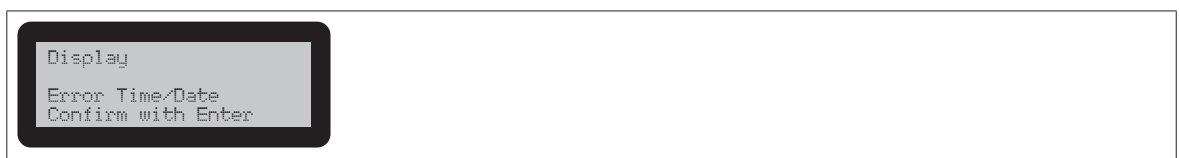

Figure 6.3.2.3/2: "Error message Date/Time"



This error message will also be displayed directly after the battery has been replaced. Confirm with "Enter" and reset the date and time.

## 6.3.2.4 System

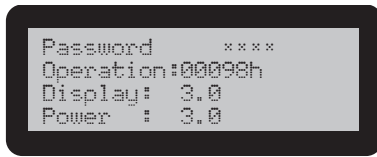

Figure 6.3.2.4/1: “System”

You can change the password for menu level 2 here. In addition, the following system data is displayed:

- Number of operating hours (“Operation”)
- Version number of display electronics (“Display”)
- Version of power electronics (“Power”)

The factory defined password for Level 2 is “1234.” Carry out the following steps to enter a new password:

1. As soon as the menu looks like the one displayed in Figure 6.3.1.3/1, press “Enter.”
2. You will be prompted to enter the old password (“Old Password”).
3. Set the first digit of the old password using the “Up/Down Arrow.” Press “Enter” to confirm the set digit. The cursor will move to the next digit. Enter the remaining digits in the same manner.
4. You will then be prompted to enter the new password. Enter the new password as described in Step 3.
5. After confirming the last digit with Enter, the new password becomes effective immediately.

## 6.3.2.5 Load factory settings

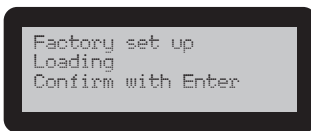

Figure 6.3.2.5/1: “Load factory settings”

Use this menu item to set the parameters back to the delivery condition. All stored switching times will be lost.

After confirming with “Enter”, the factory settings will be loaded.



6.3.3 Level 3 menu items

6.3.3.1 Limit values

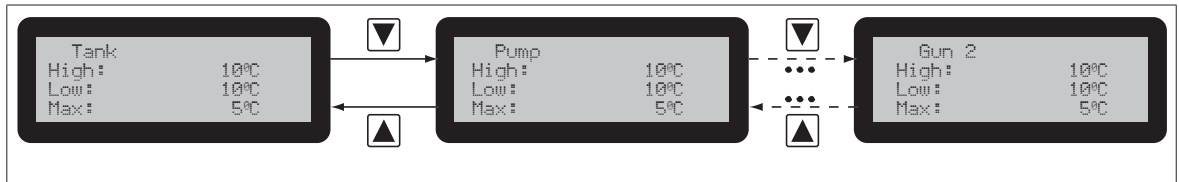

Figure 6.3.3.1/1: "Limit values"

The (temperature) limit values ("High", "Low", "Max") are specified here for the components:

- Tank
- Pump
- Hose 1 / Gun 1
- Hose 2 / Gun 2

A submenu is available for each component (see Figure 6.3.3.1/1). Navigate between the individual submenus with "Up/Down Arrow."

If the target value of a component is exceeded by the "high" value, or undercut by the "low" value, a warning will be displayed that must be confirmed with "Enter:"



Figure 6.3.3.1/2: "Limit value exceeded" (Example)

The system will continue to run in these cases.

If the temperature of a component continues to climb above the "high" value by more than the "max" value, the heaters of all components will be disconnected.

The shutdown temperature is deduced additively:

$$T_{sd} = T_{set} + T_{high} + T_{max}$$

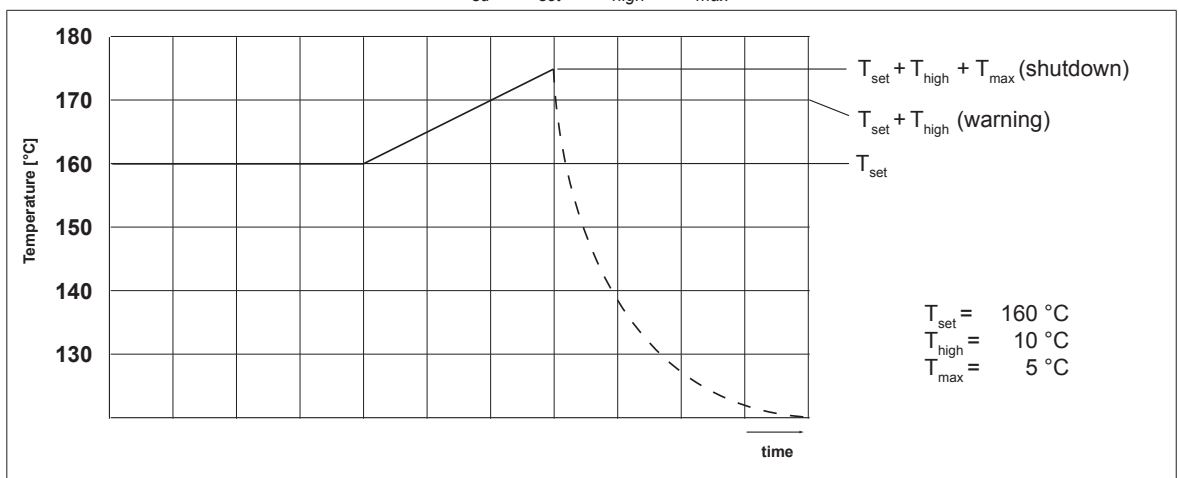
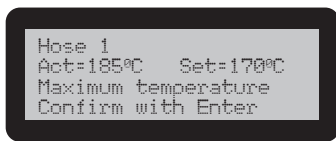

Figure 6.3.3.1/3: Cut-out behavior at overtemperature (Example)

Shutdown is accompanied by an error message that must be confirmed with "Enter."



```
Hose 1
Act=185°C   Set=170°C
Maximum temperature
Confirm with Enter
```

Figure 6.3.3.1/4: “Maximum temperature exceeded“ (Example)

Switching off the heaters due to overtemperature can have two causes:

1. While the unit was in operation, a target temperature was programmed (by accident) that was more than  $(T_{\text{high}} + T_{\text{max}})$  below the current actual temperature.
2. There is a system defect. Have the system checked/repared by a qualified service technician.

### 6.3.3.2 Waiting time

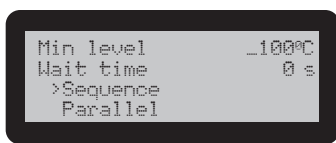

```
Min level    _100°C
Wait time    0 s
>Sequence
Parallel
```

Figure 6.3.3.2/1: “Waiting time“

This is where the how the tank system is heated up is set. Two methods are available:

#### **Sequential (factory setting)**

The tank and pump are heated first. Once the tank has reached the “lower limit” value, the hoses and pistols are heated. If a value  $>0$  is entered for “waiting time,” the heating of the hoses and pistols will be delayed by this time (in seconds) after the lower limit has been reached.

#### **Parallel**

During “parallel” heating all components are heated at the same time.

### 6.3.3.3 Pump settings



```
Release      _ 10°C
Runtime      10s
Remotecode   0
```

Figure 6.3.3.3/1: “Pump settings“

The operating behavior of the pump is specified here:

#### **Release**

The pump may only start after it has reached a minimum temperature. This minimum temperature lies below the target temperature set in the value specified at “release.“



#### **Follow-on time**

The pump follows on after every trigger by the time set here (in seconds).

#### **Switching code**

The pump is triggered by radio control (sender) in the manual units. To differentiate between the senders of neighboring tank systems, the manual units of the tank system receive a switching code. The same switching code must be defined here for the respective tank system.

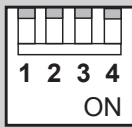
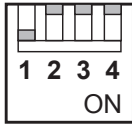
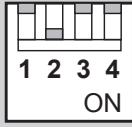
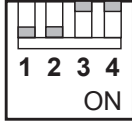
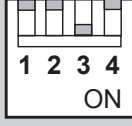
The following table shows the possible switching codes and their settings at the coding switch of the manual units:

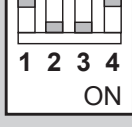
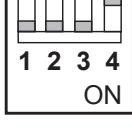
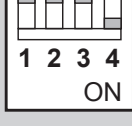
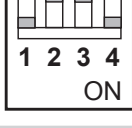
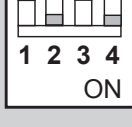
Switch code	Function	Manual unit coding
0	Pump responds to manual units of all tank systems (only useful for test operation)	
1	Pump responds to manual units with switching code "1"	
2	Pump responds to manual units with switching code "2"	
3	Pump responds to manual units with switching code „3“	
4	Pump responds to manual units with switching code „4“	
5	Pump responds to manual units with switching code „5“	
6	Pump responds to manual units with switching code „6“	
7	Pump responds to manual units with switching code „7“	
8	Pump responds to manual units with switching code „8“	
9	Pump responds to manual units with switching code „9“	
10	Pump runs in continuous operation (e.g. exhausted sender battery in manual unit until replacement is procured)	

## 6.3.3.4 Celsius / Fahrenheit



Figure 6.3.3.4/1: "Celsius / Fahrenheit"

You can select the temperature unit that will be used for all displays and entries here. Conversion occurs automatically.

## 6.3.3.5 Sensor selection

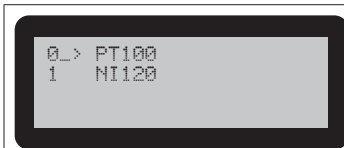

Figure 6.3.3.5/1: "Sensor selection"

Select the type of the temperature sensors used in the hoses and manual units here. Please note that mixed operation of hoses with PT100 and NI120 sensors is not possible.

## 6.3.3.6 Control parameters

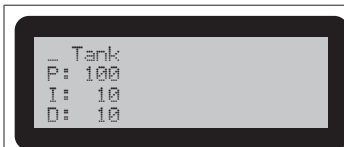

Figure 6.3.3.6/1: "Control parameters"

The control parameters (proportional, integral, and differential ratio of controller behavior) for the individual components are displayed and can be changed here as necessary. **Only implement changes** to the parameters if the components of the system (hoses, manual application units) have been replaced by units with strongly deviating temperature behaviors.

Use the integrated optimization method (see next chapter) to determine and set the parameters.



### Attention!

The controller parameters affect the entire operating behavior of the tank system. Only implement manual parameter changes in justified cases and with knowledge of how a PID controller functions. Inappropriate settings can endanger the operability of the tank system.

## 6.3.3.7 Optimization

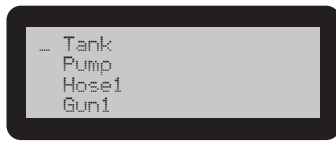

Figure 6.3.3.6/1: "Optimization"

This menu item enables the automatic determination and setting of the (PID) controller parameter for the components

- Tank
- Pump
- Hose 1
- Gun 1
- Hose 2
- Gun 2

Always start the optimization runs from the cold condition, as a heating up phase must be run through to determine the parameters.

To start an optimization run, select the desired component with "Up/Down Arrow" and press "Enter." During the optimization run, a rotating cursor will appear next to the corresponding component in the display.

Since the temperatures of the individual components interact, the determined PID parameters of a component can be easily differentiated during several successive optimization runs.

The optimization runs can be cancelled at any time using "ESC".

The following table offers an overview of the approximate times needed for optimization runs:

Component	Required time
Tank	approx. 30 min
Pump	approx. 30 min
Hoses	approx. 10 min
Manual application unit	approx. 10 min





## 7 Set-up / Retrofit

### 7.1 Removing / Replacing the Housing

Required tools:

- Slotted screwdriver 10 mm



#### Danger of burns

due to hot metal parts, hot melt material, and hot melt material vapors.

Therefore, always wear heat protection gloves during the following work steps.

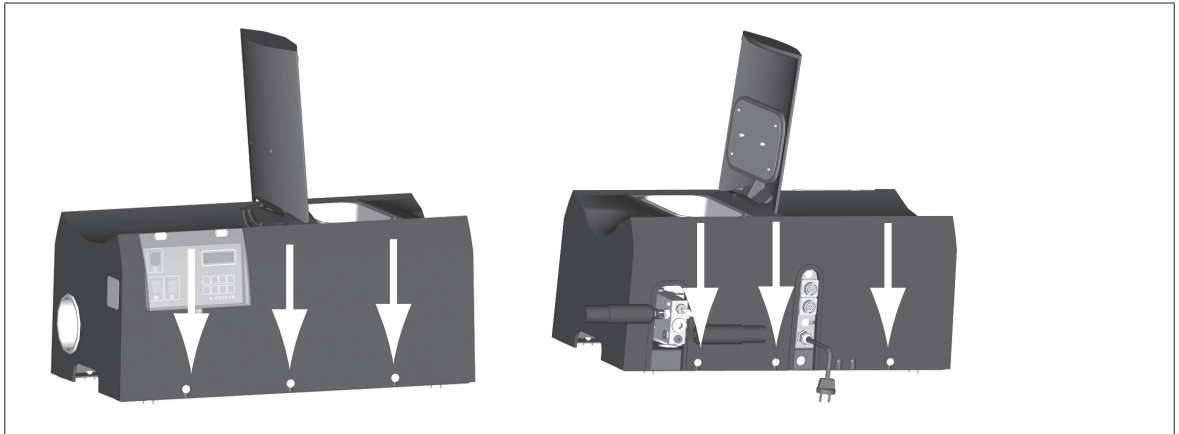
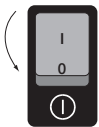

Figure 7.1/1: Releasing the housing screws

Removing/replacing the housing is only required for maintenance and repair works.

To do so, carry out the following work steps:



1. Turn off the main switch to shut down the tank system.
2. Disconnect the power plug from the outlet to switch the tank system to zero current.
3. Loosen the screws depicted in Figure 7.1/1 (6 pieces) by about 2 revolutions each.
4. Grasp the housing by the lower recessed grips and carefully pull the housing up vertically and off the tank system.
5. Carefully place the housing on a sturdy surface.

Replace the housing in the reverse order. Make sure the tank seal is correctly positioned.

### 7.2 Setting the pump pressure

#### Required tools

- Socket wrench size 8 or
- offset box wrench size 8 depth gauge
- (metal) measuring stick



#### Danger of burns!

The bypass valve used to set the pump pressure can reach temperatures of more than 200 °C.

Therefore, always wear heat protection gloves during the following work steps.

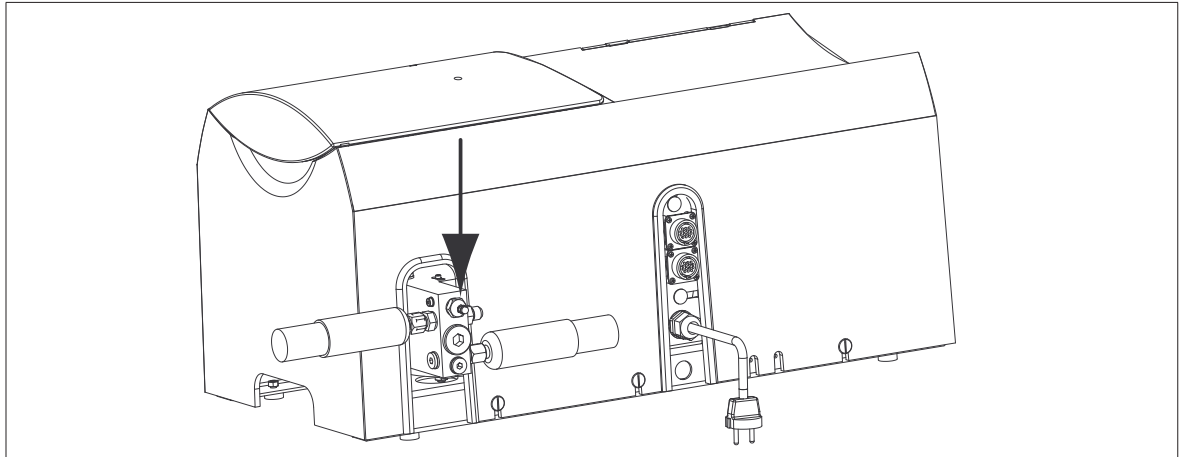

Figure 7.2/1: Setting the pump pressure



#### Info

The pump pressure strongly depends on the temperature and the viscosity of the hot melt adhesive used. The procedure described in the following therefore only serves as an approximate setting of the pump pressure.

A pressure measuring device will be needed to make an accurate setting.

Figure 7.2/2 provides you with an orientation for hot melt adhesive with a processing temperature of 180°C at a viscosity of approx. 1,000 Pas. In this case, the standard setting of the device of approx. 35 bar also applies.

To set the pump pressure, carry out the following work steps:

1. If not already done so, bring up the tank system to the operating temperature required for the utilized hot melt adhesive.
2. The visible thread length “L” of the adjusting screw is the measure for the pump pressure. Refer to the following diagram for the required length “L.”

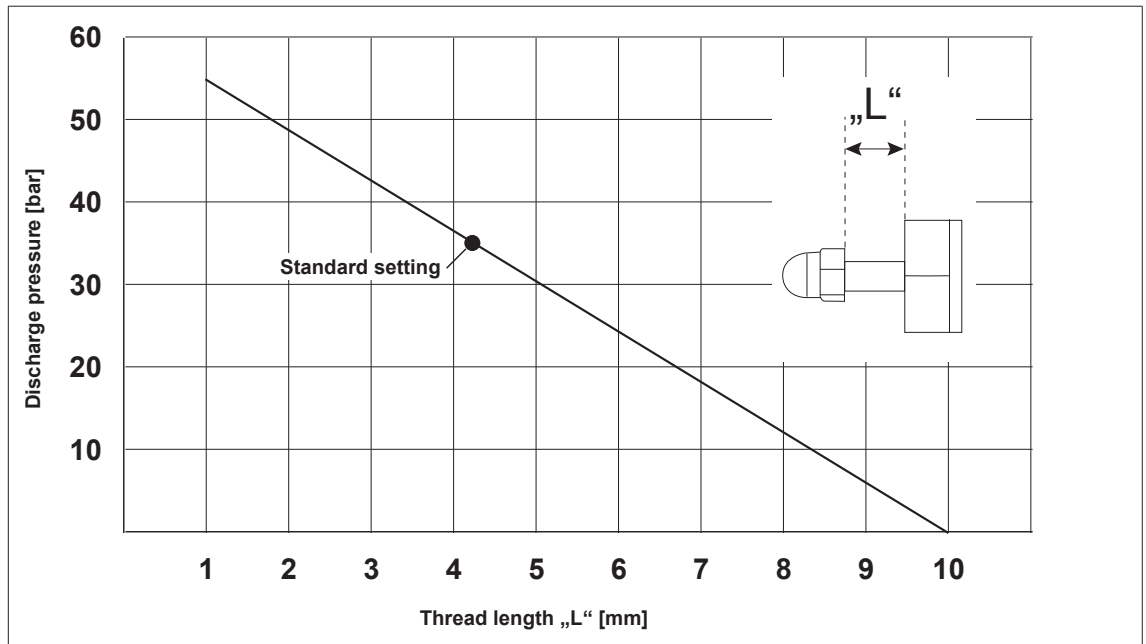

Figure 7.2/2: Diagram for setting the pump pressure

3. Adjust the required thread length “L” with wrench size 8.

### 7.3 Changing the hot melt material

Make sure first that only a small amount of the old hot melt material is in the tank.

Before changing a product, inform yourself whether the old and new hot melt materials are compatible.

If the products are compatible, the old hot melt material can be rinsed out with the new material.

If the products are not compatible, then proceed as follows:

1. Drain the tank, hose, and pistol as far as possible. Activate the trigger until the hot melt material no longer discharges.
2. Completely rinse the tank system with a cleaning agent coordinated to the new hot melt material.
3. Fill in the new hot melt material.

### 7.4 Releasing system pressure

The system pressure must be released before removing a heated hose, or for maintenance and repair works.

To do so, proceed as follows:

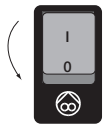

1. Turn off the pump.
2. Place a collection basin under the nozzle of the manual application unit.
3. Activate the trigger of the manual application unit until the hot melt material no longer discharges.

### 7.5 Dismantling a heated hose

**Required tools:**

- 2 open-end wrenches size 19



#### **Danger of burns**

due to hot metal parts, hot melt material, and hot melt material vapors. Therefore, always wear heat protection gloves during the following work steps.



#### **Info**

Please also note the operating instruction of the heated hose (Section 3 of this manual).

To dismantle a hose, carry out the following work steps:

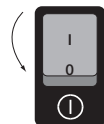

1. Heat up the tank system, or at least the hose to be dismantled and the pump to at least 100 °C. This prevents the hose from being damaged during dismantling.
2. Release the system pressure (see Chap. 7.4).
3. Turn off the tank system using the main switch.
4. Detach the electrical connection of the hose. Unscrew the cap nut of the plug and remove it.
5. Unscrew the hose from the pump using open-end wrench size 19.
6. Secure the hose connection at the pump using the second open-end wrench size 19.



#### **Attention!**

If a different hose will be attached to the tank system, then it must also be heated up to approx. 100 °C in order to prevent damage.

## 8 Maintenance / Servicing



### Danger!

Maintenance and service works may only be implemented by competent personnel. Disregarding this note can cause damage to the tank system and/or injuries to the personnel.

### 8.1 Maintenance intervals

Interval	Activity
Daily	Check the tank system for completeness
	Check all mechanical and electrical connections for tight fit.
	Remove hot melt material residues and other incrustations from the tank system.
	Check the tank for impurities and foreign objects (remove immediately as necessary).
	For tank systems with spray-air adapter kits: Drain the maintenance unit. Replace the dirty filter as needed.
Every 500 operating hours	Check the gear wheel pump for hot melt material discharge.
Every 3 years	Replace the battery of the realtime clock in the control unit (see Chap. 8.3).

### 8.2 Cleaning



### Attention!

Do not use any aggressive solvent or combustible cleaning agents to clean the tank system and its components. Such substances can cause damage to the tank system.

Using a suitable tool (e.g. cloth, soft brush, wood spatula), mechanically remove hot melt material residue and other pollution, especially from the inside walls of the tank.

To clean the conveying route, carry out the following work steps:



### Info

Before cleaning the conveying routes, have your hot melt material manufacturer inform you about suitable cleaning agents. Observe the processing data sheet and the security advice contained therein.

1. Make sure that only minor amounts of hot melt material residue is in the tank.
2. Fill the cleaning agent into the tank. Place a collection basin under the nozzle of the manual application unit.
3. Activate the trigger of the manual application unit until the cleaning agent has completely run through.
4. Fill fresh hot melt material into the tank. Continue activating the trigger of the manual application unit until only hot melt material (without any cleaning agents) is discharged.

### 8.3 Replacing the back-up battery

**Required tools:**

- 1 Slotted screwdriver 10 mm,
- 1 Phillips screwdriver size 3

**Spare part:**

- Lithium battery Varta CR 2032 or identical (3 V)

The control unit of the tank system has a back-up battery for the internal realtime clock. This back-up battery lets the realtime clock run even if the tank system is not connected to the power supply or has been disconnected.

Replace this back-up battery

- every 3 years or
- at premature exhaustion.

If the back-up battery is exhausted, the tank system will “forget” the date and time. Time-controlled operation is then no longer possible.

Premature exhaustion of the back-up battery can be recognized after receiving the following message in the display after turning on the tank system:



Figure 8.3/1: Error message for exhausted back-up battery

To replace the back-up battery, carry out the following work steps:

1. Disconnect the power plug from the tank system.
2. Remove the housing from the tank system (see Chap. 7.1).
3. Release the locking screw of the control unit as shown in Figure 8.3/2 with the Phillips screwdriver.

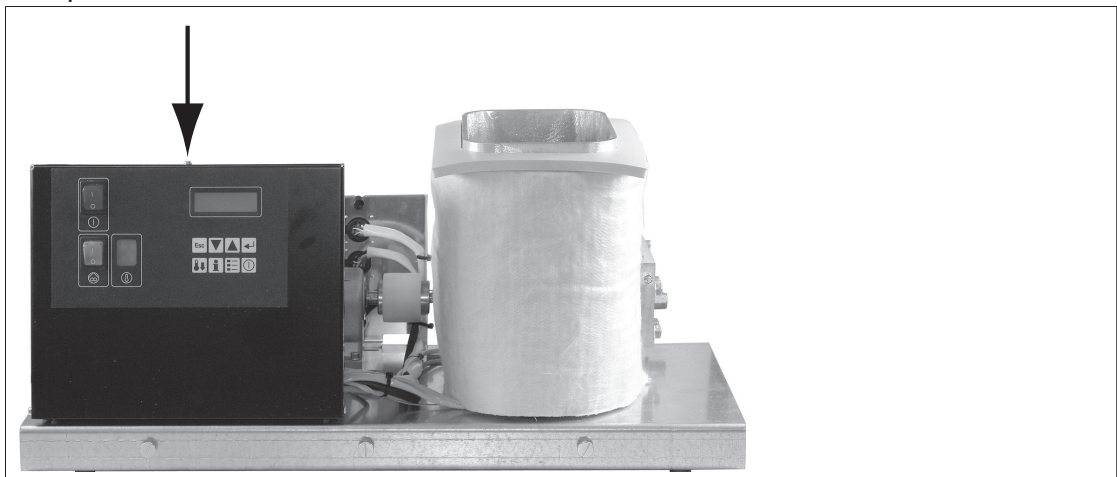

Figure 8.3/2: Opening the control unit

4. Fold down the front panel of the control unit.  
The back-up battery is located in the front area of the display circuit board (see following image)



Figure 8.3/3 Position of back-up battery



**Explosion hazard!**

While removing and replacing the back-up battery, never touch the battery with tongs or other conductive tools. This would short circuit the poles of the back-up battery. Short-circuited lithium batteries may explode!

- 5. Lightly tip the upper edge of the battery to the front against the resistance of the contact spring (approx. 30°). Pull the battery out at an angle and up out of the bracket:

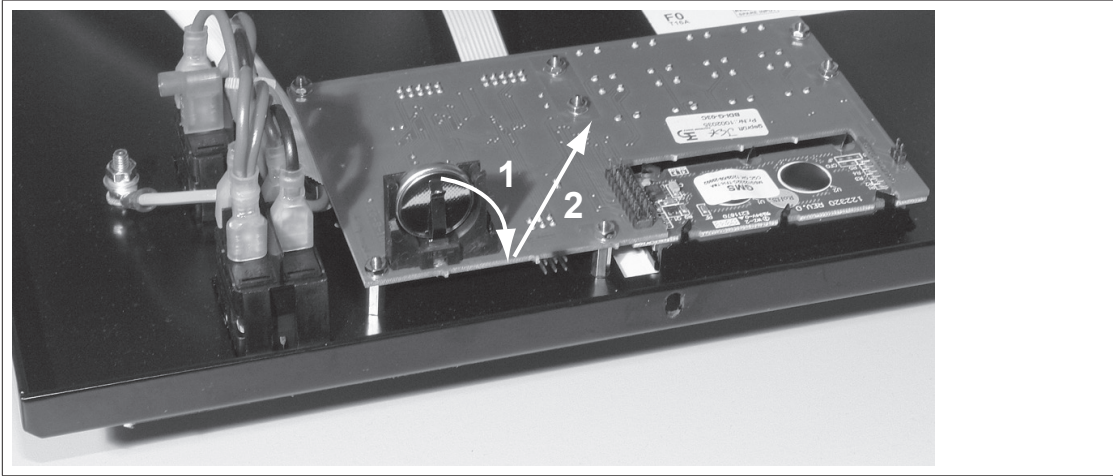

Figure 8.3/4: Removing the back-up battery

- 6. Slightly bend the contact spring of the battery bracket towards you. Place the new battery at a slight angle into the bracket. Then swing the battery into the correct (up-right) position in the bracket. In any event, observe correct polarity of the battery (plus pole points towards unit interior)!



Figure 8.3/5: Polarity of back-up battery

- 7. Close and screw on the front panel of the control unit.
- 8. Mount the housing of the tank system.

9. Connect the tank system to the power supply.
10. Turn the tank system on. Re-program the date and time (see Chap. 6.3.2.3).
11. Dispose of the drained battery in an environment-friendly manner. Comply with the local laws and regulations



Li

### 8.4 Inspection and replacement of fuses

#### Required tools:

- 1 slotted screwdriver approx. 5mm
- 1 slotted screwdriver 10mm
- 1 Phillips screwdriver size 3
- Miniature fuses, see table for values

#### Spare part:

There are fuses for all important modules on the power section of the control unit. In the event of a breakdown of individual functions (pump, heater, etc.) check the associated fuse first.

To inspect/replace the fuse, carry out the following work steps:

1. Disconnect the mains plug from the tank system.
2. Remove the housing from the tank system (see Chap. 7.1).
3. Release the locking screw of the control unit as shown in Figure 8.3/2 (see p. 37) with the Phillips screwdriver.
4. Fold down the front panel of the control unit.

The power section is mounted to the bottom of the control unit (see following figure):



Figure 8.4/1: Position of power section

5. Figure 8.4/2 and the following table show the position and assignment of the fuses F1...F8. All fuses are commercially available miniature fuses (5 x 20mm).



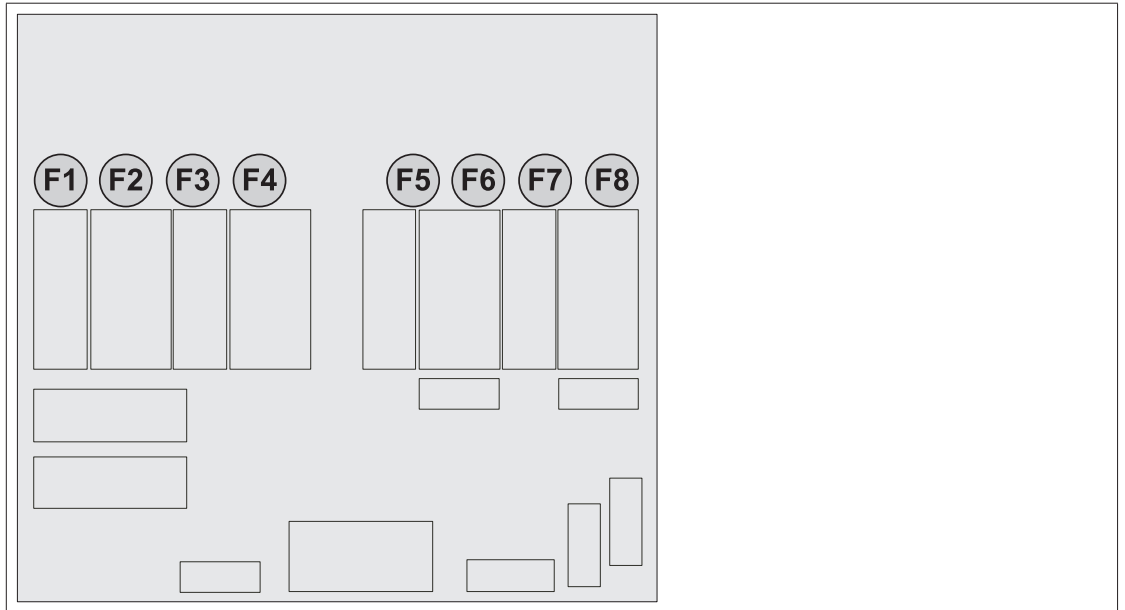

Figure 8.4/2: Position of fuses on the power section

Fuse	Value	Function
F1	4 A FF (quick acting)	Pump motor
F2	10 A FF (quick acting)	Tank heater
F3	4 A FF (quick acting)	Pump heater
F4	0.63 A M (medium time-lag)	Controller
F5	6.3 A FF (quick acting)	Heater Hose 1
F6	4 A FF (quick acting)	Heater Pistol 1
F7	6.3 A FF (quick acting)	Heater Hose 2
F8	4 A FF (quick acting)	Heater Pistol 2

6. Insert the screwdriver (approx. 5mm) in the slot of the upper part of the relevant fuse holder. Lightly press down the upper part of the fuse holder; turn the upper part approx. 30° counter-clockwise.
7. The upper part with the fuse can now be removed.
8. Inspect the fuse for continuity, e.g. using a multimeter in the smallest resistance measuring range (usually 200 Ω). Replace the defective fuse.
9. Reassembly is carried out in reverse order.



**Attention!**

**Never** replace (not even for trial purposes) a defective fuse with a different component (e.g. a piece of wire).

The safe operation of the system cannot be guaranteed after such manipulation: consequential damages are probable!

Only use the fuse types listed in the table above.

## 9 What happens if...

For occurring malfunctions and faults, first check





- the power supply and all electrical connections
- whether the main switch and the pump switched have been turned on
- whether the temperature values for the utilized hot melt adhesive have been set correctly

If defects occur, a protective circuit protects the tanks in any case from being heated to temperatures exceeding 260 °C.

### 9.1 General errors

Fault	Possible cause	Remedy
Breakdown of a single component (e.g. hose heater, tank heater, controller, ...)	Associated fuse is defective	Check fuse, replace as necessary (see Chap. 8.4)
Temperature fluctuates strongly or application system does not heat No or insufficient hot melt material is discharged	Defective temperature sensor	Replace
	Defective control unit	Replace
	Hot melt tank is empty	Fill up
	Hot melt material viscosity is too high	Observe processing notes of hot melt material manufacturer
	Application unit nozzle is clogged	Clean
	Pump pressure is set too low	Increase pump pressure (see Chap. 7.2)
	Defective gear wheel pump	Replace
	Filter cartridge polluted	Replace (see Chap. 3.3 in Part 7 „Maintenance Schedule“ of this manual)
Pump does not work	Pump has not been released yet. Indicator light (4) does not light up	Wait until temperature has been reached
	Hot melt material has not melted or viscosity of hot melt material is too high	Allow hot melt material to heat thoroughly, increase working temperature as necessary
	Motor overheats The thermal switch in the motor has switched off	Allow motor to cool down and determine cause
	Start-up capacitor of motor is defect	Have start-up capacitor replaced (only by qualified service personnel!)
	Defective motor	Have motor replaced (only by qualified service personnel!)
	Fuse F1 is defective	Check fuse, replace as necessary (see Chap. 8.4)

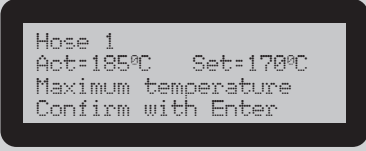
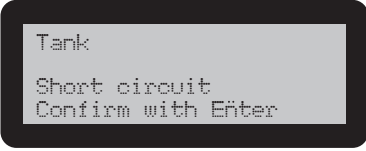
9.2 Error messages in the display

Display	Cause	Remedy
	<p>The temperature of the displayed component (here: "Hose 1") has exceeded the permissible temperature range in normal operation. The message must be confirmed with "Enter"</p>	<ul style="list-style-type: none"> <li>• Check whether the default value for the target temperature during running operation („normal operation“) of the affected component (see Chap. 6.3.2.3) was set to less than the current actual temperature minus the overtemperature value (see Chap. 6.3.3.1, "High").</li> <li>• Turn off the tank system and allow it to cool down. If the error occurs again after 30 minutes, notify Service.</li> </ul>
	<p>The temperature of the displayed component (here: "Hose 1") has undercut the permissible temperature range in normal operation. The message must be confirmed with "Enter"</p>	<ul style="list-style-type: none"> <li>• Check whether the default value for the target temperature during running operation („normal operation“) of the affected component (see Chap. 6.3.2.3) was set to greater than the current actual temperature plus the overtemperature value (see Chap. 6.3.3.1, "Low").</li> <li>• Notify Service if this setting is okay.</li> </ul>
	<p>The temperature of the displayed component (here: "Hose 1") has exceeded the permissible maximum temperature in normal operation. The message must be confirmed with Enter</p>	<ul style="list-style-type: none"> <li>• Check whether the default value for the target temperature during running operation („normal operation“) of the affected component (see Chap. 6.3.2.3) was set to less than the current actual temperature minus the maximum temperature value (see Chap. 6.3.3.1, "Max").</li> <li>• Turn off the tank system and allow it to cool down. If the error occurs again after 30 minutes, notify Service.</li> </ul>
	<p>The temperature sensor of the affected component is defective. The message must be confirmed with "Enter"</p> <p>The heater of the component is turned off.</p>	<ul style="list-style-type: none"> <li>• Notify Service.</li> </ul>
	<ul style="list-style-type: none"> <li>• The affected component (here: "Hose 1") has not been connected (electrically).</li> </ul> <p>or</p> <ul style="list-style-type: none"> <li>• The temperature sensor of the component is defective.</li> </ul>	<ul style="list-style-type: none"> <li>• Establish the electrical connection of the component.</li> <li>• Notify Service.</li> </ul>
	<p>The control unit has "lost" the current date.</p>	<ul style="list-style-type: none"> <li>• Set the correct date and time.</li> <li>• If the error occurs again: Replace the back-up battery of the control unit (see chap. 8.3).</li> </ul>

## What happens if...

Display	Cause	Remedy
 <p>Power Overtemperature Confirm with Enter</p>	<p>The cooling element in the control unit has exceeded the permissible maximum temperature. The message must be confirmed with "Enter"</p> <p>All heaters are switched off.</p>	<p>Turn off the tank system and allow it to cool down. If the error occurs again after 30 minutes, notify Service.</p>

## 10 Accessories

### 10.1 Spray-air adapter kit

#### 10.1.1 Overview

The spray-air adapter kit is required for the “spray” models of the HB 5010 tank system.

It regulates, cleans, and dewateres the compressed air required for “spray” operation.

Additional requirements for spray operation are:

- Heatable “spray” hoses
- “Spray” manual application units

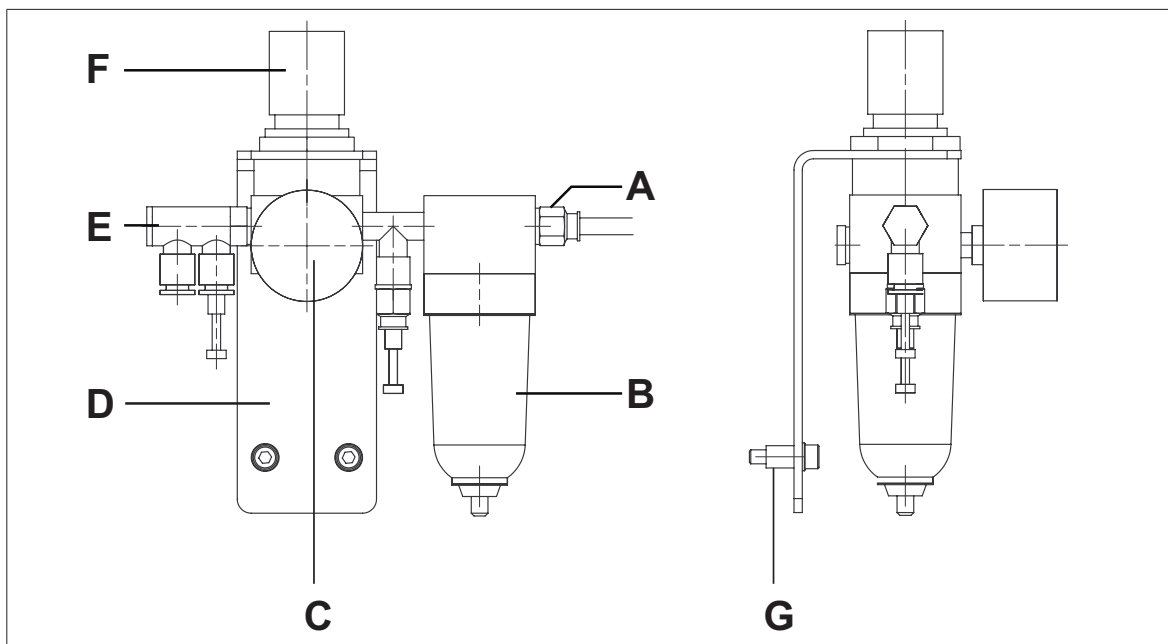

Figure 10.1.1/1: Spray-air adapter kit in overview

A	Quick coupler for hose 6/4 Input pressure max. 16 bar
B	Maintenance unit with dewatering valve
C	Pressure display (output pressure)
D	Holding plate
E	Plug nipple for compressed air output for compressed air hose NW6
F	Adjusting wheel for output pressure
G	Fastening screws with spacer sleeves

## 10.1.2 Assembly

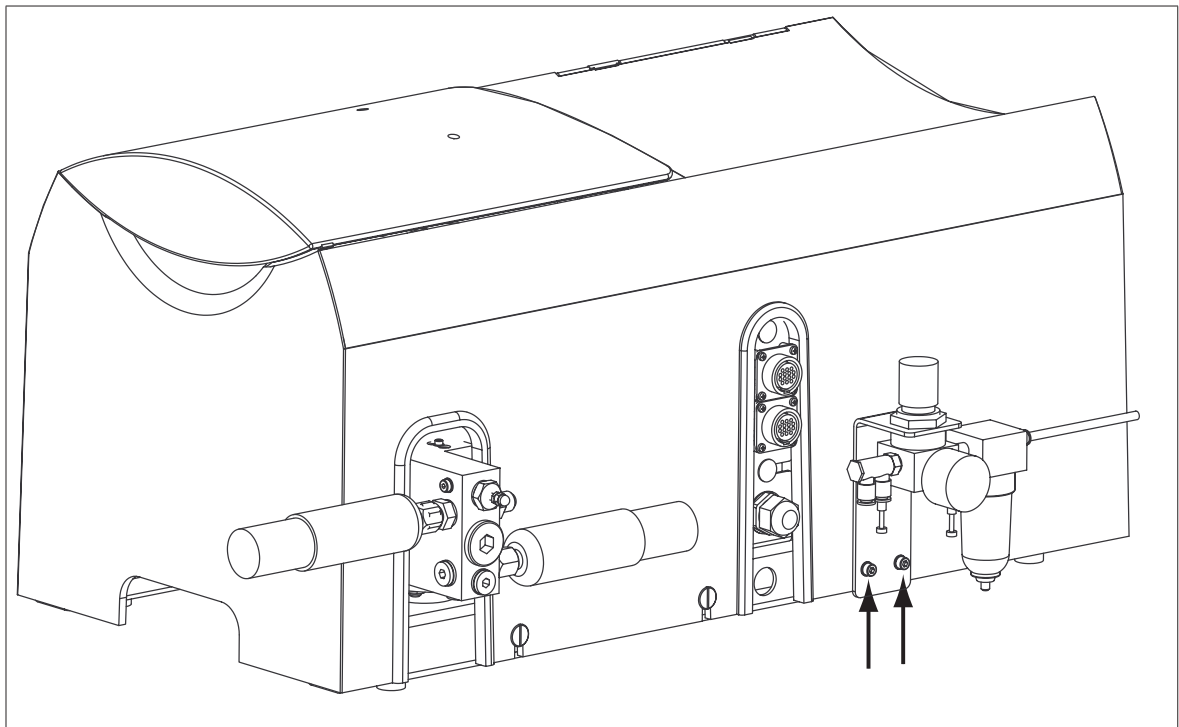

Figure 10.1.2/1: Assembly of spray-air adapter kit

To assemble the spray-air adapter kit to the tank system, implement the following steps:

1. Insert the supplied fastening screws through the holding plate.
2. Slide the spacer sleeves onto the screws inserted through the holding plate.
3. Screw on the spray-air adapter kit as shown in Figure 10.1.2/1. The corresponding threaded holes have been provided on the frame of the tank system.
4. Connect the compressed air connections of the heated hoses to the plug nipples (“E” in Figure 10.1.1/1). If only one heated hose will be connected, then the remaining plug nipple must be sealed with a blind plug.
5. Connect the quick-release fastener of the compressed air line to nipple “A” (see Figure 10.1.1/1).

## 10.1.3 Setting the optimum working pressure

The adjusting wheel “F” is used to set the working pressure (see Figure 10.1.1/1). The adjustment range is 0 to 3.5 bar.

The optimum working pressure for spray operation is between 1.4 and 3.0 bar.

Determine the optimum working pressure for your use by repeatedly turning the adjusting wheel and making trial sprays.

The pressure display always shows the current working pressure.

**10.1.4 Maintenance**

Maintenance of the spray-air adapter kit is limited to the daily draining of the inspection glass which collects the precipitated water from the supplied compressed air.

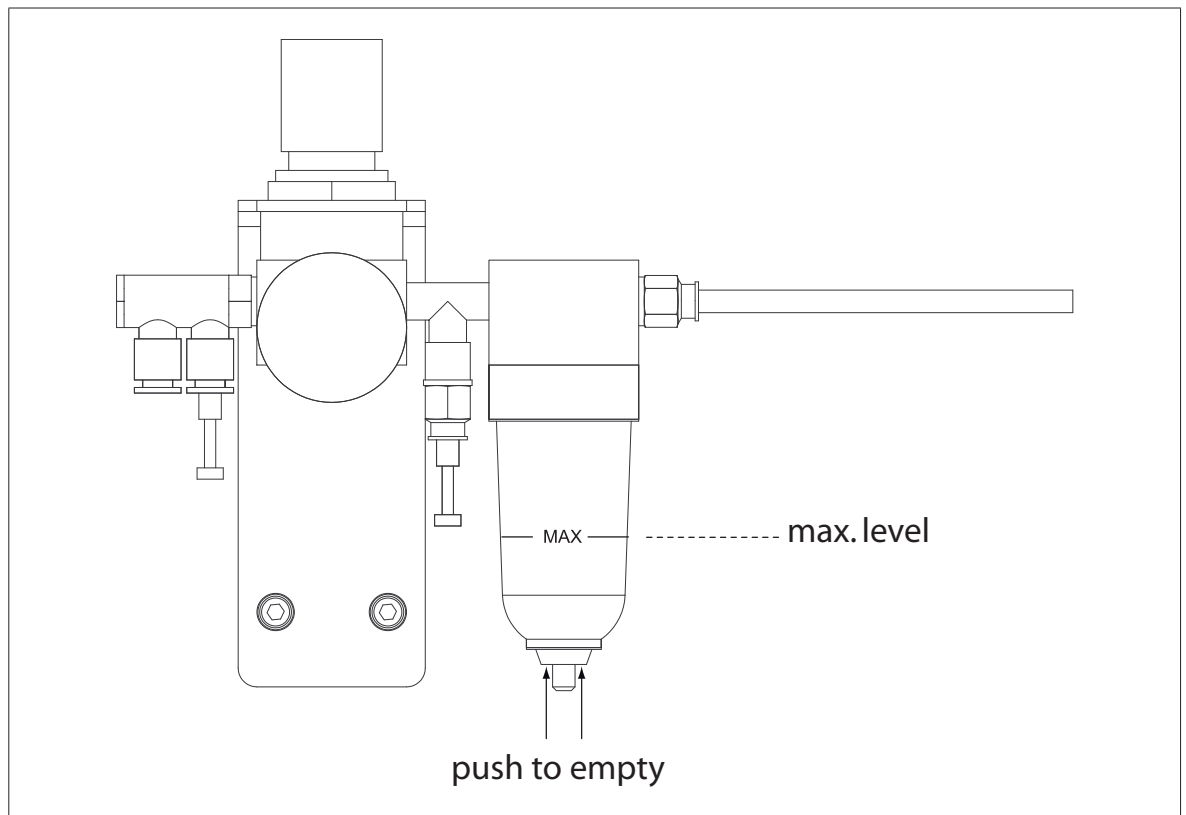

Figure 10.1.4/1: Spray-air adapter kit maintenance

### 11 Repairs

Repairs other than those described in these operating instructions may only be implemented by competent persons commissioned by the manufacturer or otherwise competent persons under utilization of original BÜHNEN spare parts.

### 12 Warranty

The unit was developed and manufactured according to the latest state of technology. The first purchaser receives warranty on function, material, and processing according to statutory regulations. Normal wear and tear is excepted.

The warranty is void if improper handling, use of violence, repairs by third parties and the installation of spare parts other than the original has been determined.

The warranty extends to servicing or replacing according to our choice. Warranty beyond our scope of delivery is excluded, as we do not have any influence on the competent and expert use of the unit.

Please observe our terms and conditions!

### 13 Disposal



Take the unit, packaging, and accessories to an environmentally friendly recycling center (in accordance with Directive 2002/96/EG of the European Parliament and the Council of January 27, 2003).







BÜHNEN GmbH & Co. KG  
Hinterm Sielhof 25  
28277 Bremen • Germany  
Phone: +49 (0) 421 51 20 - 125  
Fax: +49 (0) 421 51 20 - 260  
kleben@buehnen.de  
www.buehnen.de

## Operating Instructions

Heatable hose

# HP Standard



<b>1</b>	<b>Specific security advice .....</b>	<b>5</b>
1.1	Possible dangers.....	5
1.2	Intended use .....	5
1.3	Notes on safe operation .....	5
<b>2</b>	<b>Technical Data .....</b>	<b>7</b>
2.1	Type key / Available Versions.....	7
2.2	Technical data .....	7
2.3	Dimensioned drawings.....	8
2.4	Pin assignment.....	9
<b>3</b>	<b>Construction and Function .....</b>	<b>11</b>
3.1	Construction .....	11
3.2	Function .....	12
3.3	Chemical resistance of adhesive hose.....	12
3.4	Temperature stability .....	12
<b>4</b>	<b>Installation .....</b>	<b>13</b>
4.1	Connection / Removal.....	13
4.2	Guidance notes .....	13
4.2.1	Bending radius .....	13
4.2.2	Further tips on hose guidance.....	14
<b>5</b>	<b>Maintenance .....</b>	<b>17</b>
5.1	Maintenance intervals .....	17
5.2	Cleaning .....	17
<b>6</b>	<b>Repairs .....</b>	<b>19</b>
<b>7</b>	<b>Warranty .....</b>	<b>19</b>
<b>8</b>	<b>Disposal .....</b>	<b>19</b>



# 1 Specific security advice

## 1.1 Possible dangers

---



### **Danger of burns**

due to hot metal parts, hot melt material, and hot melt material vapors.  
Therefore, always wear heat protection gloves.

---

## 1.2 Intended use

Heatable hoses are used as flexible connections between machines or machine parts. They are used to transport melted hot melt material, such as from a tank system to the manual application unit.

---



### **Attention!**

Heatable hose type HP is only permitted for operation with BÜHNEN manual application units of type HR/HS.

Separation from and connection to manual application units may only be implemented by electrically competent personnel.

---

## 1.3 Notes on safe operation

- The maximum permissible working temperature ( $T_{max}$ , see type plate) may not be exceeded. Too high temperatures will cause the pressure load capacity to sink. This could destroy the hose.
  - Release the system pressure before dismantling the heatable hose (see Part 2 of this manual).
- 



### **Danger!**

**Before every maintenance or repair work on the heatable hose**, remove the mains plug from the tank system.

Otherwise, an adjacent radio control could accidentally activate the pump during the maintenance or repair work.

**Danger of burning caused by hot melt adhesive!**

---





## 2 Technical Data

### 2.1 Type key / Available Versions



Bild 2.1/1: Type key

### 2.2 Technical data

Design	Standard	High temperature (HT)
Supply voltage	230 VAC / 50...60 Hz	
Heating capacity (P)	up to 3 m hose length: 130 W/m as of 3 m hose length: 100 W/m	
Max. operating temperature ( $T_{max}$ )	200 °C	250 °C
Temperature sensor	PT100	
Pressure load capacity ( $P_{max}$ ) for 8 mm hose core	The stated values have been established by measurement in stretched condition without movement. The values will change for mechanical loads. Especially short, frequently very high pressure peaks have a negative impact.	
Bursting pressure at 24°C Max. hot melt material pressure:	900 bar	900 bar
up to 24 °C	200 bar	250 bar
at 100 °C	180 bar	225 bar
at 200 °C	160 bar	200 bar
at 250 °C	-	188 bar
Max. spray air pressure ( $P_{max}$ ) (only with Version HS manual application units)	5 bar	
Fitting	galvanized steel, 9/16-18 UNF thread, size 19	

2.3 Dimensioned drawings

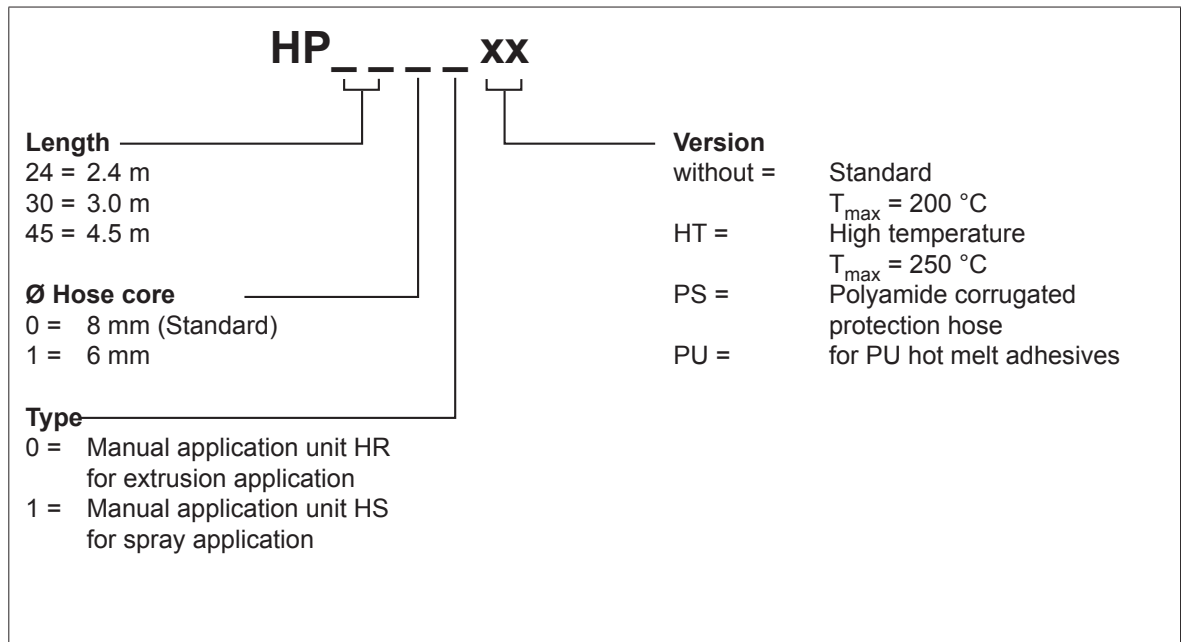
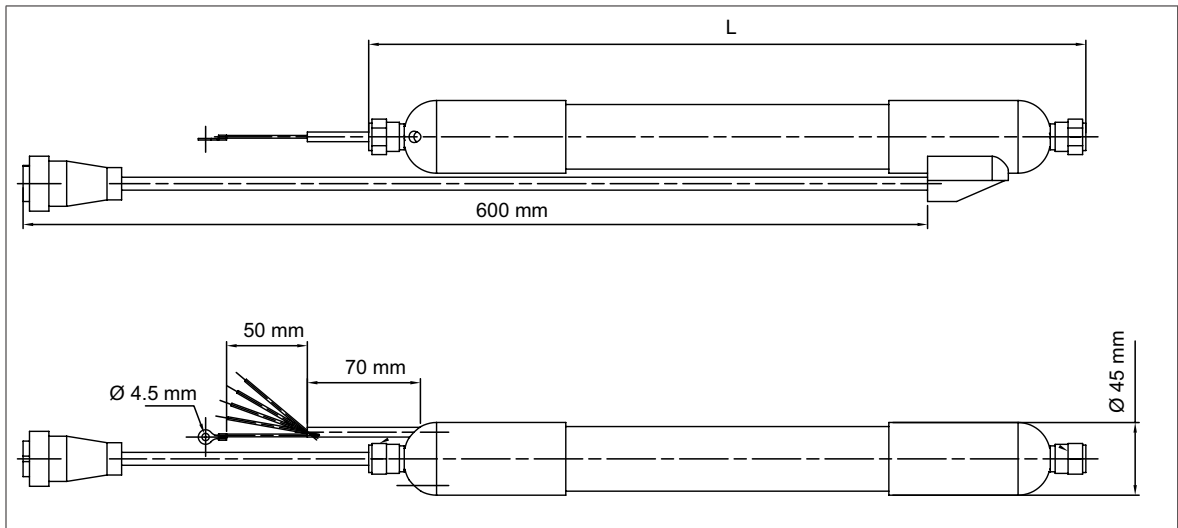

Figure 2.3/1: Dimensioned drawing, Extrusion Version

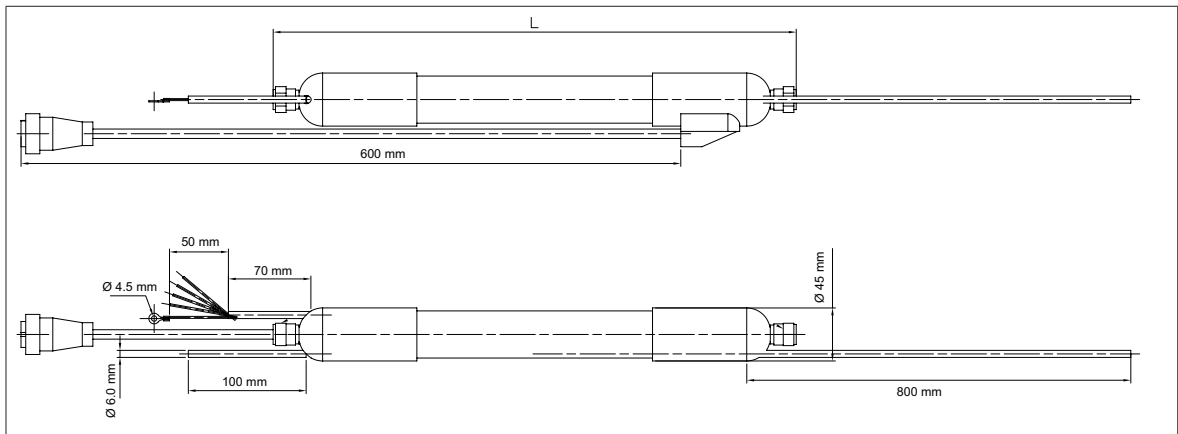

Figure 2.3/2: Dimensioned drawing, Spray Version

## 2.4 Pin assignment

Pin type: AMP 14-pole, pins

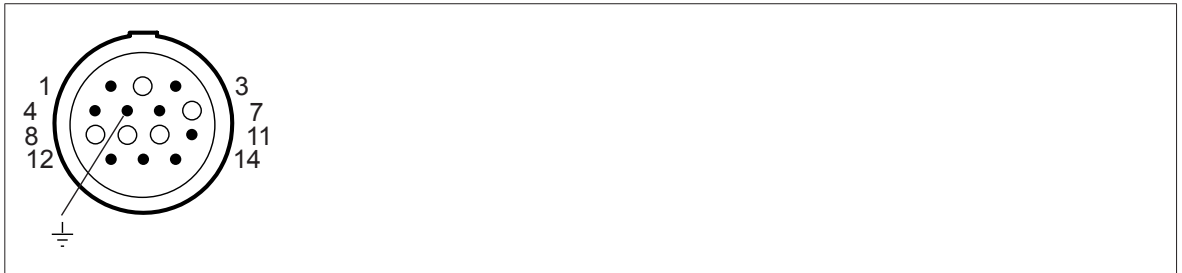

Figure 2.4/1: Pin assignment

Pin	Color	Function
1	brown	Heater Hand unit (N)
2	free	
3	blue	Heater Hand unit (L1)
4	grey	Sensor hand unit (Pt100)
5	green/yellow	Protective Earth (PE)
6	grey	Sensor hand unit (Pt100)
7	free	
8	free	
9	free	
10	free	
11	black	Sensor hose (Pt100)
12	black	Sensor hose (Pt100)
13	yellow	Heater hose (L1)
14	violet	Heater hose (N)



**3**  
**3.1**      **Construction and Function**  
**Construction**

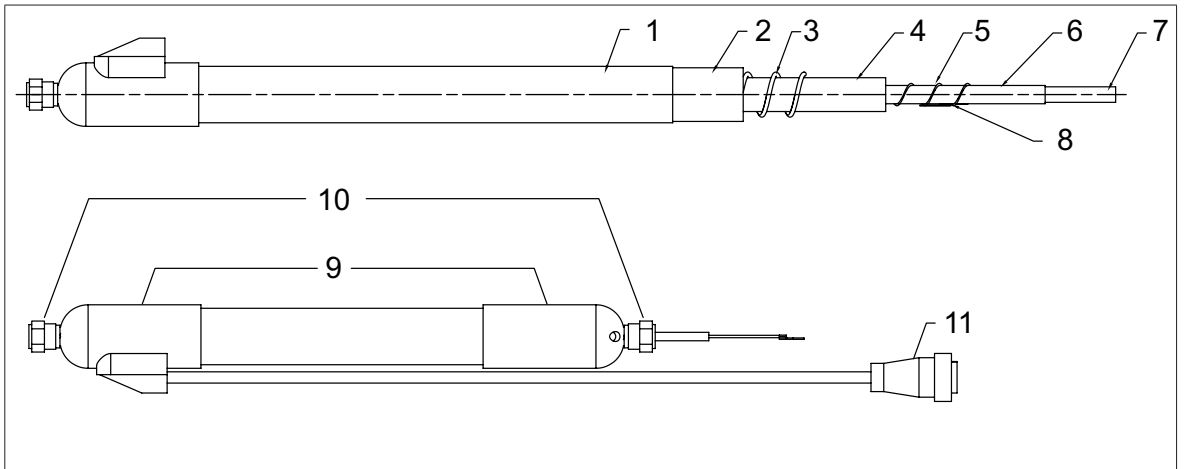

Figure 3.1/1: Mechanical construction of hose (Extrusion Version)

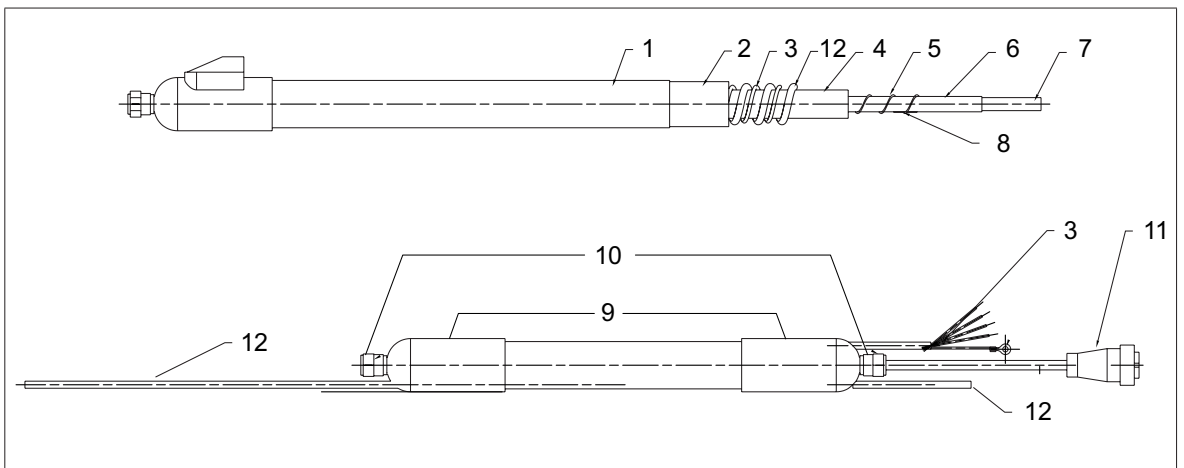

Figure 3.1/2: Mechanical construction of hose (Spray Version)

Ser. No.	Designation
1	Protective braid (polyamide black or PA corrugated hose)
2	Silicone foam
3	Brush shunts
4	Insulation (fiberglass braid)
5	Heating conductor
6	Stainless steel fiber
7	Adhesive hose
8	Temperature sensor Pt100
9	End caps
10	Connection fittings (steel, galvanized), size 19
11	Connector plug (AMP 14-pole)
12	PTFE hose for spray air (only Spray Version)

### 3.2 Function

The basis of the heatable hoses is the adhesive hose (7) through which the hot melt material flows. The hose consists of high-quality PTFE with a smooth surface.

Since the adhesive hose does not have great compressive strength it is covered by a stainless steel fiber braid (6). The connection fittings of galvanized steel are pressed with the entire construction.

The heating conductors (5) consist of high-quality heating conductor alloys that are covered by a protective conductor braid. Fiberglass braid (4) that covers the heating conductors is used as heat insulation.

The PTFE insulated brush shunts are coiled around this construction in a spiral shape.

A heat stabilizing silicone foam (2) with fine-pored cell structure covers the entire construction that is protected by a polyamide protective braid (1). The connection sides of the hose are provided with stable temperature end caps made of silicone.

A temperature sensor (Pt100) is installed between the heater and stainless steel fiber that reports the current hose temperature to the control electronics.

Heatable hoses in the spray version also include a PTFE hose (12) for spray air.

### 3.3 Chemical resistance of adhesive hose

PTFE is resistant to almost all media.

Water will diffuse through the walls in minor amounts.



#### Attention!

When using hot melt materials containing fluorinated hydrocarbons, oils, alkali metals, or halogens, have the respective manufacturer advise you about PTFE compatibility.

Unsuitable hot melt materials can damage the adhesive hose.

---

### 3.4 Temperature stability

The polyamide protective braiding ([1] in Figure 3.1/1) is stable up to 160 °C. Local over-temperatures can occur by bundling several heatable hoses or by touching hot machine parts. For that reason, comply with the notes in Chap. 4.2.2.



#### Attention!

The maximum permissible temperature (given as  $T_{\max}$  on the type plate) may not be exceeded.

The too high temperatures causes the pressure load capacity of the heated hose to sink, which can cause the hose to be damaged or destroyed (see also Chap. 2.2, "Technical Data".).

---

## 4 Installation



### Attention!

The heatable hose may only be installed by competent personnel.  
See the operating instructions of the tank system for more details.

### 4.1 Connection / Removal

Assembling the heatable hoses to the tank system is described in detail in the operating instructions of the tank system.

### 4.2 Guidance notes

#### 4.2.1 Bending radius

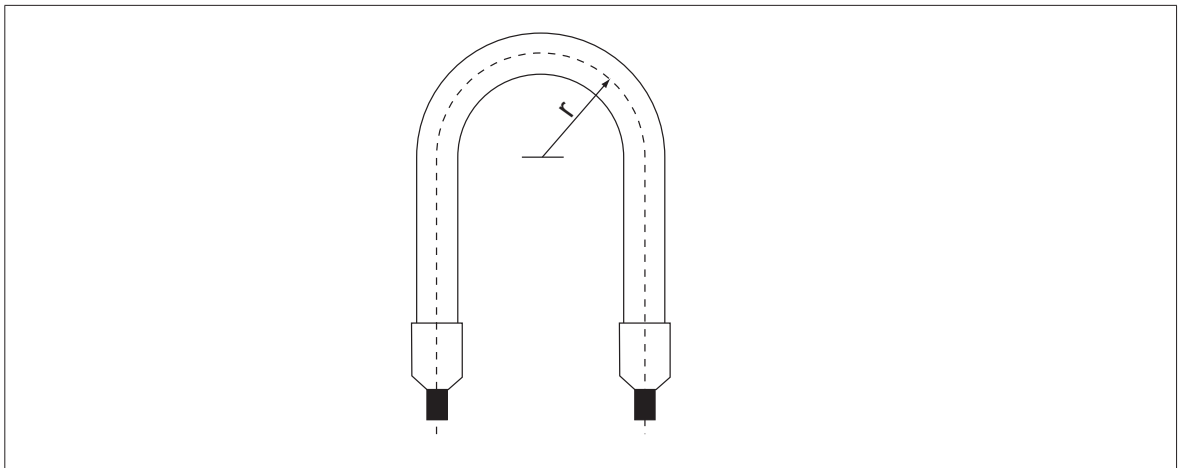

Figure 4.2.1/1: Permissible bending radius of the heatable hose

The minimum permissible bending radius of the heated hose is 160 mm.

Please also observe the following notes

- Undercutting the minimum permissible bending radius, buckling, strong torsion loads (twisting) and S turns can cause the destruction of the hose.
- Movement and bending stresses may not occur directly at the connections.

## 4.2.2 Further tips on hose guidance

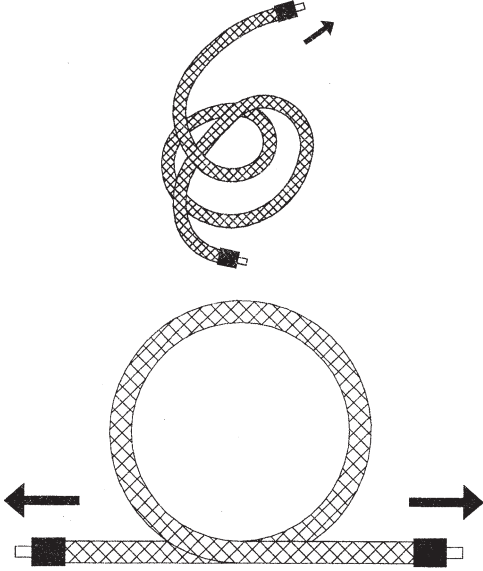
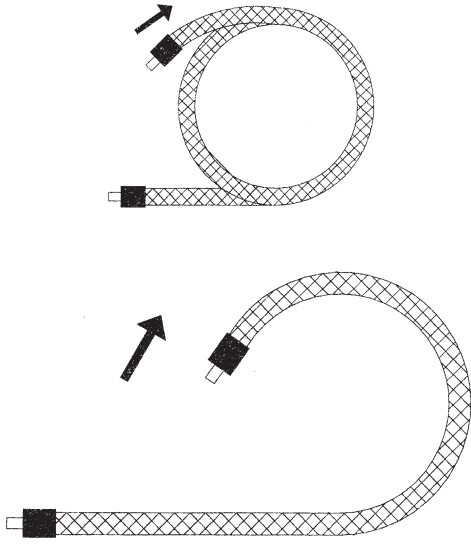
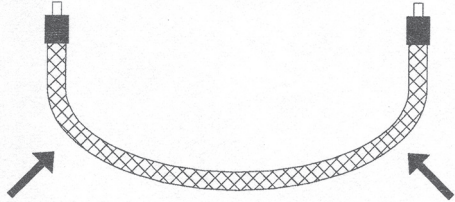
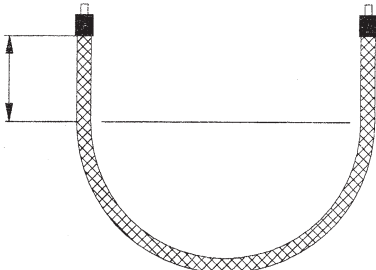
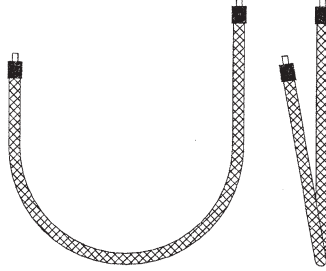
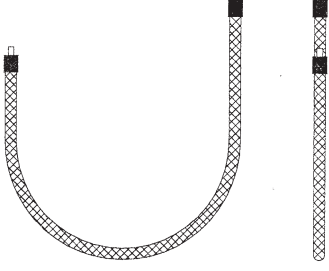
Wrong	Right
 <p data-bbox="279 922 839 1003">By pulling the ends of rolled up hoses, torsion stress occurs. The smallest permissible bending radius can be undercut!</p>	 <p data-bbox="922 922 1372 952">Unwind the ring. (Do not pull off the hose)</p>
 <p data-bbox="290 1326 833 1355">A too short hose will buckle at the connection ends</p>	 <p data-bbox="865 1326 1433 1444">Plan to leave a straight piece (length approx. 5 x hose diameter) at the connection ends. A greater bending radius will increase the service life of the hose.</p>
 <p data-bbox="290 1774 833 1892">Torsion movement leads to destruction of the heatable hose. This occurs frequently due to incorrect installation, but above all due to twisting the hose during assembly.</p>	 <p data-bbox="874 1774 1423 1859">Let the hose axes run parallel during laying. Lay the hose in such a way that the direction of movement runs on a level with the hose axes.</p>

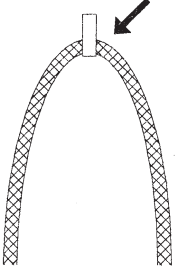
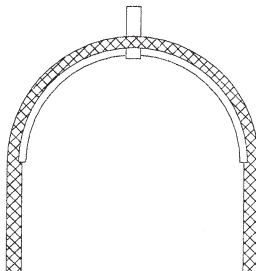
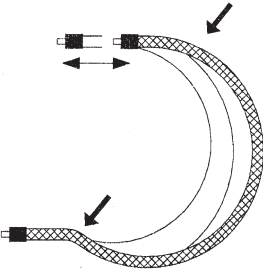
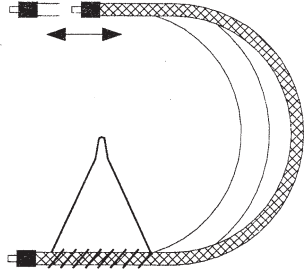
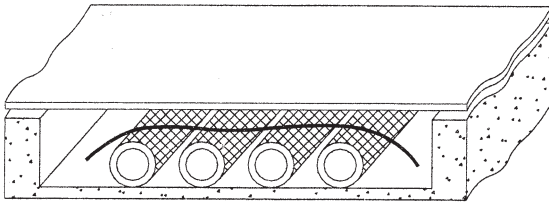
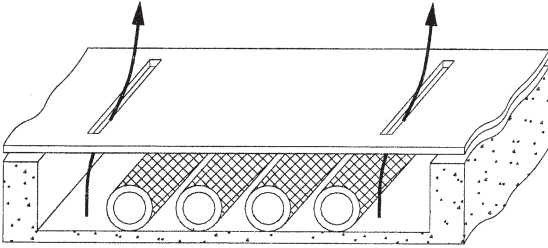
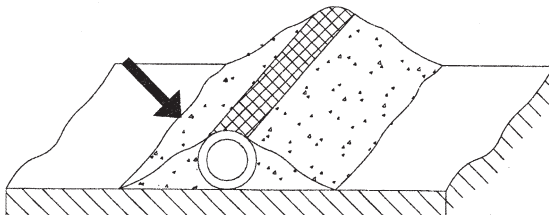
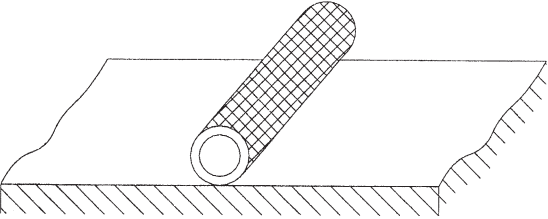

Wrong	Right
 <p>Guidance clips can cause buckling to the hose and bending stress.</p>	 <p>Remedy: Use a saddle or deflection pulley with corresponding diameter.</p>
 <p>An unfavorable installation will let the hose sag.</p>	 <p>Remedy: Spiral hose suspension</p>
 <p>Heat accumulation can occur when laying the hoses in a closed canal or duct.</p>	 <p>The hoses may not touch each other. Make sure you provide for adequate aeration.</p>
 <p>If the hoses are covered with powdery substances, local overheating will occur.</p>	 <p>Clean the hoses at regular intervals.</p>

# Installation

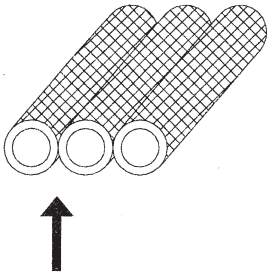
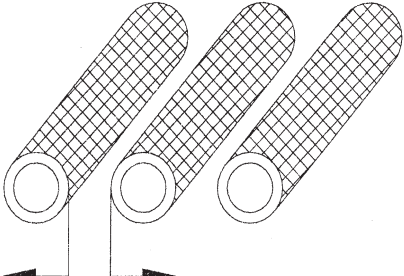
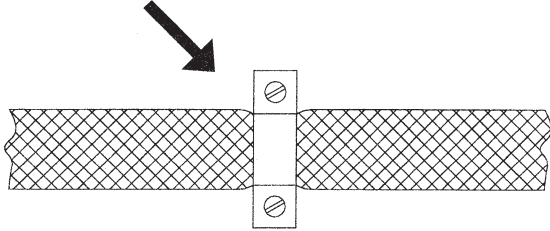
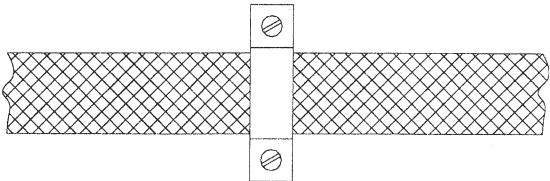
Wrong	Right
 <p data-bbox="280 577 839 636">Bundling or laying the hoses with contact will lead to overheating at these contact sites.</p>	 <p data-bbox="960 577 1337 604">Lay these hoses far enough apart.</p>
 <p data-bbox="280 918 839 976">Squeezing the hoses caused by brackets can damage the hoses.</p>	 <p data-bbox="871 918 1426 1003">Select the bracket with the matching diameter. Tighten the bracket enough so that the hose is secured but not squeezed.</p>

## 5 Maintenance

---



### Attention!

Maintenance works may only be implemented by competent personnel.

---

### 5.1 Maintenance intervals

Interval	Activity
Daily	Check the hoses for leak tightness.
	Check all mechanical and electrical connections for tight fit.
	Remove hot melt material residues and other incrustations.

### 5.2 Cleaning

---



### Attention!

Do not use any aggressive solvent or combustible cleaning agents to clean the hoses. Such substances can cause damage to the hoses.

---

Using a suitable tool (e.g. cloth, soft brush, wood spatula), mechanically remove hot melt material residue and other pollution.

The heatable hose can also be cleaned by rinsing it with a suitable cleaning agent (see operating instructions of the basic unit).



## 6 Repairs

Repairs other than those described in these operating instructions may only be implemented by competent persons commissioned by the manufacturer or otherwise competent persons under utilization of original BÜHNEN spare parts.

## 7 Warranty

The unit was developed and manufactured according to the latest state of technology. The first purchaser receives warranty on function, material, and processing according to statutory regulations. Normal wear and tear is excepted.

The warranty is void if improper handling, use of violence, repairs by third parties and the installation of spare parts other than the original has been determined.

The warranty extends to servicing or replacing according to our choice. Warranty beyond our scope of delivery is excluded, as we do not have any influence on the competent and expert use of the unit.

Please observe our terms and conditions!

## 8 Disposal



Take the unit, packaging, and accessories to an environmentally friendly recycling center (in accordance with Directive 2002/96/EG of the European Parliament and the Council of January 27, 2003).



BÜHNEN GmbH & Co. KG  
Hinterm Sielhof 25  
28277 Bremen • Germany  
Phone: +49 (0) 421 51 20 - 125  
Fax: +49 (0) 421 51 20 - 260  
kleben@buehnen.de  
www.buehnen.de

## Operating instructions

Manual application unit with radio control

**Type HR (Extrusion)**

**Type HS (Spray)**





<b>1</b>	<b>Specific security advice .....</b>	<b>5</b>
1.1	Possible Dangers .....	5
1.2	Intended use .....	5
1.3	Notes on safe operation .....	5
<b>2</b>	<b>Technical Data .....</b>	<b>7</b>
2.1	Product identification .....	7
2.2	Circuit diagram .....	8
<b>3</b>	<b>Construction and Function .....</b>	<b>9</b>
3.1	Construction Type HR (Extrusion Version).....	9
3.2	Construction Type HS (Spray Version).....	10
3.3	Function .....	11
3.4	Special features .....	11
<b>4</b>	<b>Initial operation .....</b>	<b>13</b>
4.1	Installation .....	13
4.2	Setting the temperature.....	13
<b>5</b>	<b>Operation .....</b>	<b>15</b>
5.1	General notes.....	15
5.2	Discharging the hot melt material.....	15
5.3	Setting the spray pattern (HS version only) .....	16
<b>6</b>	<b>Set-up / Retrofit .....</b>	<b>17</b>
6.1	Replacing the nozzle .....	17
6.1.1	Nozzle UNF 3/8 (HR version).....	17
6.1.2	Swirl nozzle (HS version) .....	17
6.2	Assembling/dismantling the heatable hoses .....	18
6.3	Setting the preliminary/secondary air.....	20
6.4	Setting the switching code .....	21
<b>7</b>	<b>Maintenance / Servicing .....</b>	<b>23</b>
7.1	Maintenance intervals .....	23
7.2	Cleaning .....	23
7.3	Replacing the transmitter battery .....	24
<b>8</b>	<b>What happens if.....</b>	<b>25</b>
<b>9</b>	<b>Accessories .....</b>	<b>27</b>
9.1	Adapter for extrusion application (for HS version only).....	27
9.1.1	Converting to extrusion application .....	27
<b>10</b>	<b>Repairs .....</b>	<b>29</b>
<b>11</b>	<b>Warranty .....</b>	<b>29</b>
<b>12</b>	<b>Disposal .....</b>	<b>29</b>



# 1 Specific security advice

## 1.1 Possible Dangers

---



### Danger of burns

due to hot metal parts, hot melt material, and hot melt material vapors.  
Therefore, always wear heat protection gloves.

---

## 1.2 Intended use

The manual application unit is used to apply regulated amounts of hot melt materials (thermoplastic materials such as hot melt adhesives, waxes, etc.) in extrusion form (Type HR) or as a spray (Type HS).

When processing reactive hot melt adhesives, such as polyurethane (PU) hot melt adhesives, we recommend placing the nozzle in a paraffin oil bath during longer work breaks.

---



### Attention!

The manual application units of the types HR and HS are only permitted for operation with heatable hoses of the type BÜHNEN HP ....

Separation from and connection to heatable hoses may only be implemented by electrically competent personnel.

---

## 1.3 Notes on safe operation

- Never point the operational manual application unit towards yourself or at other persons.
- 



### Danger!

**Before every maintenance or repair work on the heatable hose**, remove the mains plug from the tank system.

Otherwise, an adjacent radio control could accidentally activate the pump during the maintenance or repair work.

Danger of burning caused by hot melt adhesive!

---



## 2 Technical Data

Designation	Version HR for extrusion application	Version HS for spray application
Parts No.	WCH 1147-F	WCH 1148-F
Supply voltage	230 VAC/50...60 Hz	
Weight	approx. 850 g	approx. 970 g
Heating capacity	120 W	
Type of protection (in acc. with DIN IEC 34 T5)	IP42	
Protection class (in acc. with DIN VDE 0720)	I (Protective earth)	
Max. operating temperature	210 °C	
Type of heating	High-performance heating cartridge	
Temperature sensor	Pt100	
Overtemperature protection	Overtemperature fuse, trigger temperature 260 °C	
Heatable hoses	HP 2400/2.4 m HP 3000/3.0 m HP 4500/4.5 m	HP 2401/2.4 m HP 3001/3.0 m HP 4501/4.5 m
Max. adhesive pressure	40 bar	
Max. spray air pressure	-	3.0 bar
Nozzle	Extrusion nozzle with UNF 3/8" thread	Spray nozzle set, consisting of: air cap, retainer ring, swirl nozzle
Available nozzles	0.8/1.0/1.2/1.5/2.0/3.0 mm	0.8/1.0/1.5/2.0 mm
Adapter for extrusion application		FDH 0423

### 2.1 Product identification

These operating instructions apply to all manual applications units with the following illustrated type plate.

The type plate is located on the side of the grip casing.

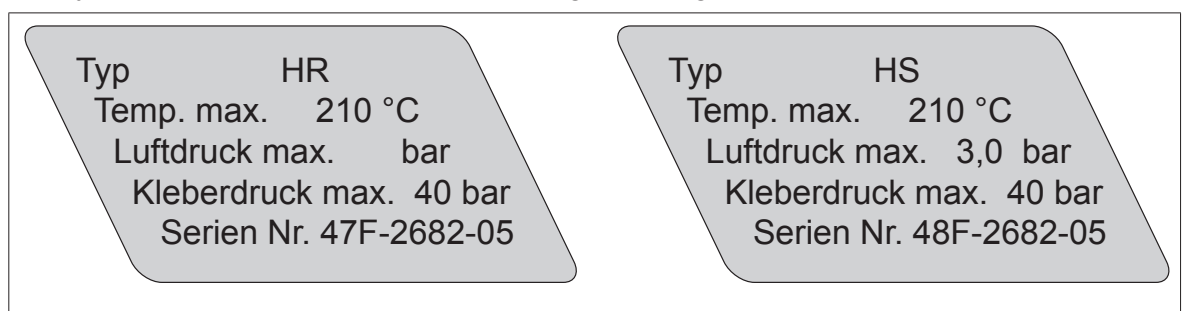

Figure 2.1/1: Type plate on unit (examples, HR version left, HS version right)

2.2 Circuit diagram

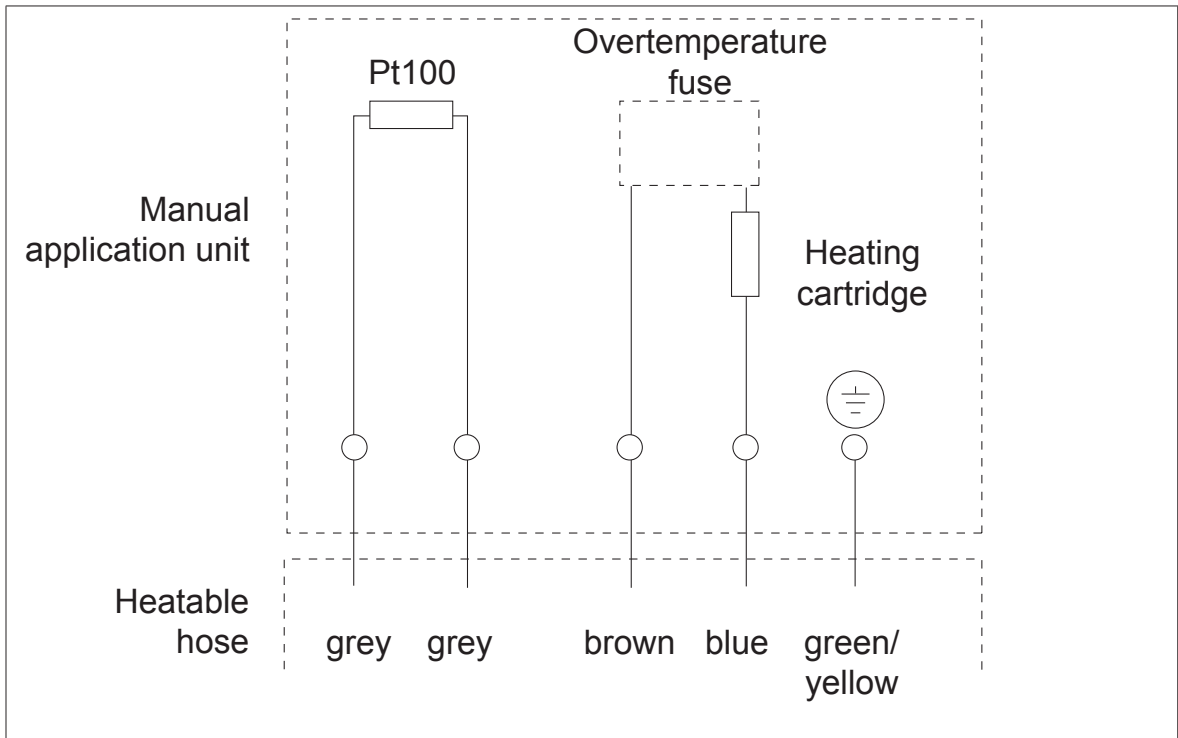

Figure 2.2/1: Circuit diagram

**3 Construction and Function**  
**3.1 Construction Type HR (Extrusion Version)**

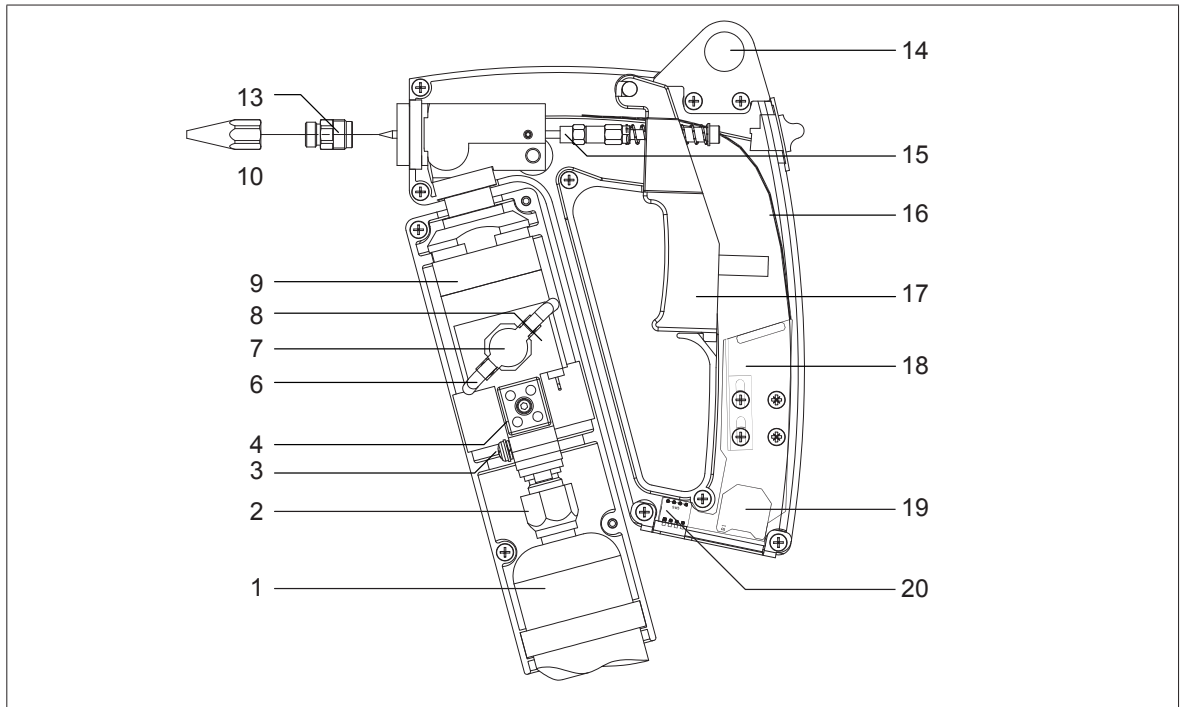

Figure 3.1/1: Mechanical construction of manual application unit Type HR

Ser. No.	Designation
1	Heatable hose, type HP Standard
2	Connection fittings
3	Protective earth terminal
4	Connection terminal temperature sensor
6	Temperature sensor
7	Overtemperature circuit-breaker
8	Heating cartridge
9	Heating cylinder
10	Nozzle UNF 3/8
13	Nozzle holder
14	Suspension eye
15	Nozzle needle
16	Transmitting antenna
17	Trigger
18	Transmitter
19	Battery holder with lithium battery
20	Coding switch for unit address

## 3.2 Construction Type HS (Spray Version)

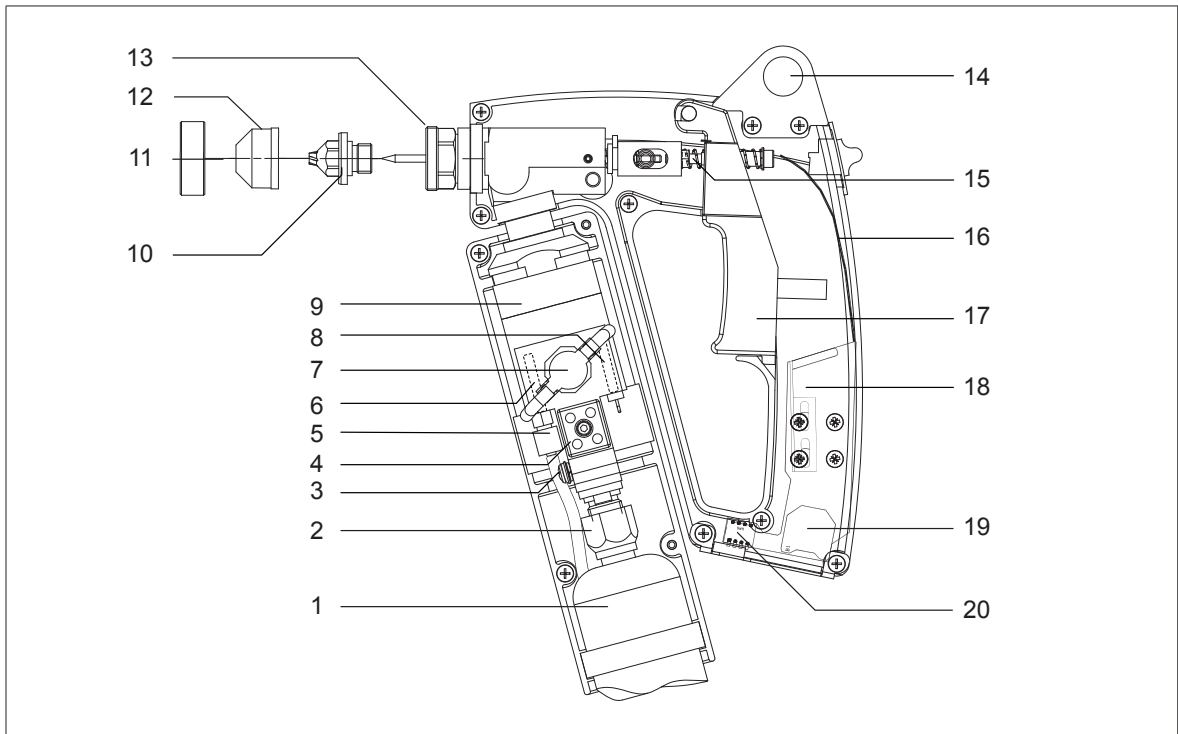

Figure 3.2/1: Mechanical construction of manual application unit Type HS

Ser. No.	Designation
1	Heatable hose, type HP Standard
2	Connection fittings
3	Protective earth terminal
4	Connection terminal temperature sensor
5	Spray air hose with connection
6	Temperature sensor
7	Overtemperature circuit-breaker
8	Heating cartridge
9	Heating cylinder
10	Swirl nozzle
11	Retainer ring
12	Air cap
13	Spray adapter
14	Suspension eye
15	Nozzle needle
16	Transmitting antenna
17	Trigger
18	Transmitter
19	Battery holder with lithium battery
20	Coding switch for unit address



### 3.3 Function

The manual application unit consists of a rigid part permanently connected with the heatable hose and a rotating part.

The part connected with the heatable hose contains

- the heater,
- the temperature sensor,
- the overtemperature circuit-breaker, and
- all electrical connections.

The rotating part has

- the nozzle system,
- the trigger,
- the transmitter,
- the replaceable battery (lithium cell) as power supply for the transmitting electronics and
- the coding switch to set the unit address.

The hot melt material flows through the connection fitting (2) of the heatable hose into the heating cylinder (9) that is heated by the heating cartridge (8).

The hot melt material flows into the nozzle head from there. In its idle state, the nozzle needle (15) closes the nozzle holder (13), or, the swirl nozzle.

When the trigger is activated, the nozzle needle opens the nozzle holder/swirl nozzle and the hot melt material is discharged. The transmitter is activated at the same time and transmits the activation of the trigger to the basic unit so that the pump can be controlled as needed. A non-contacting and therefore wear-free magnet activates the transmitter.

The temperature of the heating element is constantly monitored by the temperature sensor (6) and transferred to the control electronics in the basic unit. The control electronics use the information to control the heating cartridge.

If the temperature of the heating cylinder exceeds 260 °C (e.g. if the control electronics are defective), the overtemperature circuit-breaker (7) will interrupt the power supply of the heating element for safety reasons.

### 3.4 Special features

#### General

- The rotating part can be turned endlessly (360°) around the stationary part.
- No annoying lines in the outer area of the manual application unit due to radio transmission of the triggering signal.

#### Type HS (Spray version)

- The spray air is pre-heated in the heating hose/cylinder (1 resp. 9) and is discharged time-shifted (preliminary and secondary air). This ensures an optimal, drip-free spraying pattern.
- The spray application can be converted to extrusion application at any time by using an adapter.



## 4 Initial operation

---



### Attention!

Initial operation may only be implemented by competent personnel.

---

### 4.1 Installation

The HR/HS type manual application unit is permanently connected with a heatable hose upon delivery.

After the heatable hose has been assembled to the basic unit, the manual application unit is immediately operational without requiring additional measures.

### 4.2 Setting the temperature

The temperature of the hot melt material is set using the control electronics of the tank system.

---



### Info

Please do not set the temperature higher than the processing temperature prescribed/recommended by the manufacturer.

This prevents thermal damage to the hot melt adhesive.

---

The manual application unit has its own heater only used to retain the temperature of the hot melt material. It is not possible to additionally heat up the hot melt material in the manual application unit. In normal operation, the hot melt material flows through the heating element too quickly for that.



## 5 Operation



### Attention!

Operation may only be implemented by competent personnel.

### 5.1 General notes



#### Wear safety gloves!

Danger of burn injuries due to hot metal parts, in the area of the heat insulation (2), and due to the discharged hot melt material.

To avoid burning yourself while operating the manual application unit, always wear heat protection gloves.



#### Danger of mucous membrane irritation due to vapors!

Even during prescribed processing, hot melt adhesives give off vapors that can have an annoying odorous effect.

Therefore, only operate the tank system in well ventilated rooms. Observe the processing bulletin and the safety data sheet of the hot melt adhesive manufacturer.

While operating the manual application unit, always comply with the following notes:

- Hang up the manual application unit by the suspension eye (14) when interrupting work.
- Immediately turn off the tank system if the function is disrupted. Have qualified personnel check the tank system.

### 5.2 Discharging the hot melt material

To discharge the hot melt material, carry out the following work steps:

1. Make sure that the tank system with all components has been thoroughly heated (approx. 30 min after turning on).
2. Make sure that the triggering safeguard is always in the bottom position (yellow marking not visible).
3. Activate the trigger (17).
4. Regulate the discharge amount by activating the trigger for longer/shorter periods. The discharge amount can be additionally varied by
  - selecting another nozzle,
  - moving the nozzle more slowly or more quickly over the work piece,
  - changing the processing temperature, or
  - changing the operating pressure (max. 55 bar).

## 5.3 Setting the spray pattern (HS version only)

The spray pattern depends on the operating pressure of the tank system and the setting of the spray air pressure.

Determine the optimum setting by turning the adjusting wheel at the spray air adapter kit and repeated trials.

To set the adjusting wheel, carry out the following work steps:

- Unlock the adjusting wheel by pulling it up as far as it will go.
- Implement the desired setting.
- Lock the adjusting wheel against unintentional re-adjustment by pressing it back down in the initial position.

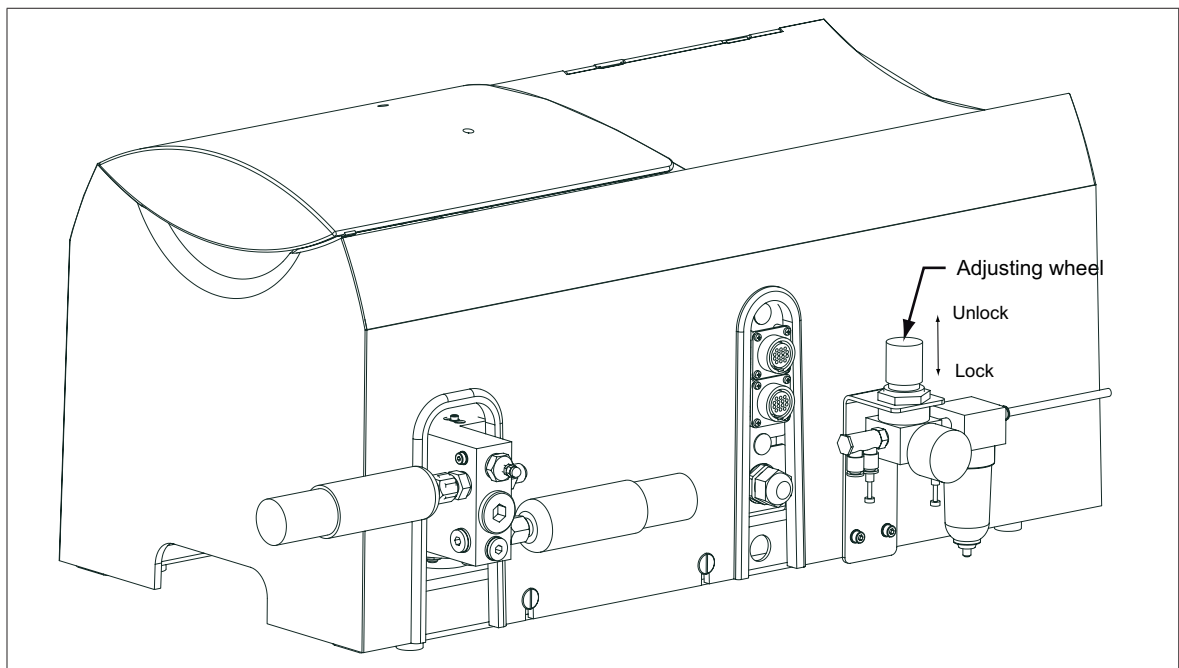

Figure 5.3/1: Adjusting wheel for spray air setting (HS version)

## 6 Set-up / Retrofit



### Attention!

Setting up and retrofitting works may only be implemented by competent personnel.

### 6.1 Replacing the nozzle



#### Wear safety gloves!

Danger of burns due to hot metal parts and due to discharged hot melt material. To avoid burning yourself while setting up/retrofitting the manual application unit, always wear heat protection gloves.

#### 6.1.1 Nozzle UNF 3/8 (HR version)

**Required tool:** 1 open-end wrench size 11  
1 box wrench size 11, offset

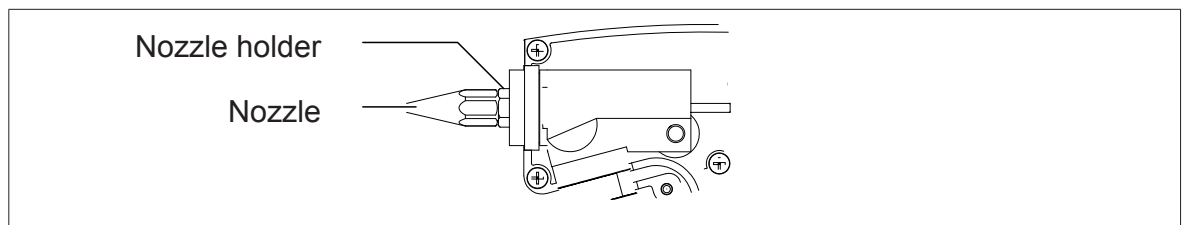

Figure 6.1.1/1: Replacing the nozzle (HR version)

To replace the nozzle, carry out the following work steps:

1. Heat up the manual application unit to approx. 100 °C.
2. **Turn off the tank system and disconnect the mains plug.**
3. Secure the nozzle holder with box wrench size 11.
4. Unscrew the nozzle with open-end wrench size 11.
5. Screw on the new nozzle by hand first.  
Wait about 2 minutes until the new nozzle has been thoroughly heated.
6. Tighten the new nozzle **without using force**.

#### 6.1.2 Swirl nozzle (HS version)

**Required tool:** 1 open-end wrench size 13  
1 open-end wrench size 22

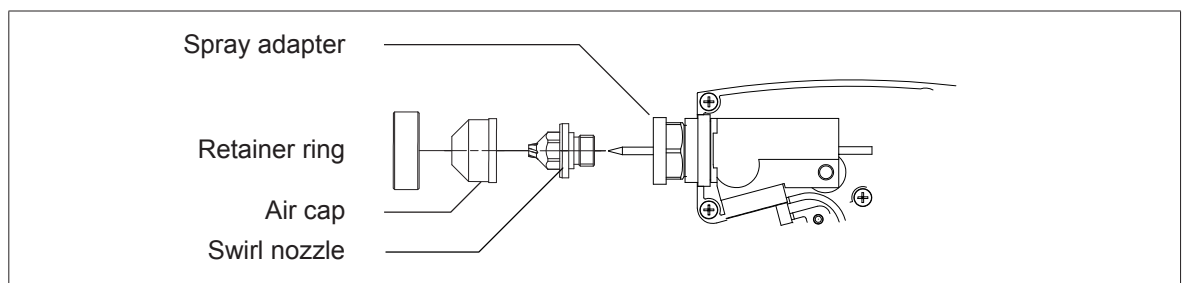

Figure 6.1.2/2: Replacing the swirl nozzle (HS version)

To replace the swirl nozzle, carry out the following work steps:

1. Heat up the manual application unit to approx. 100 °C.
2. **Turn off the tank system and disconnect the mains plug.**
3. Unscrew the retainer ring.

4. Remove the air cap.
5. Unscrew the swirl nozzle.
6. Screw on the new swirl nozzle by hand first.  
Wait about 2 minutes until the new swirl nozzle has been thoroughly heated.
7. Tighten the new swirl nozzle **without using force**.
8. Replace the air cap.
9. Tighten the retainer ring **without using force**.

### 6.2 Assembling/dismantling the heatable hoses



#### **Wear safety gloves!**

Danger of burns due to hot metal parts and due to discharged hot melt material. To avoid burning yourself while assembling/dismantling the heated hose, always wear heat protection gloves.



#### **Danger of electric shock!**

Disconnect the power plug from the tank system before carrying out the following work:  
Connecting and terminated electrical connections may only be implemented by competent electricians.

#### **Required tools:**

- 1 open-end wrench size 17
- 1 open-end wrench size 19
- 1 Phillips screwdriver
- 1 slotted screwdriver

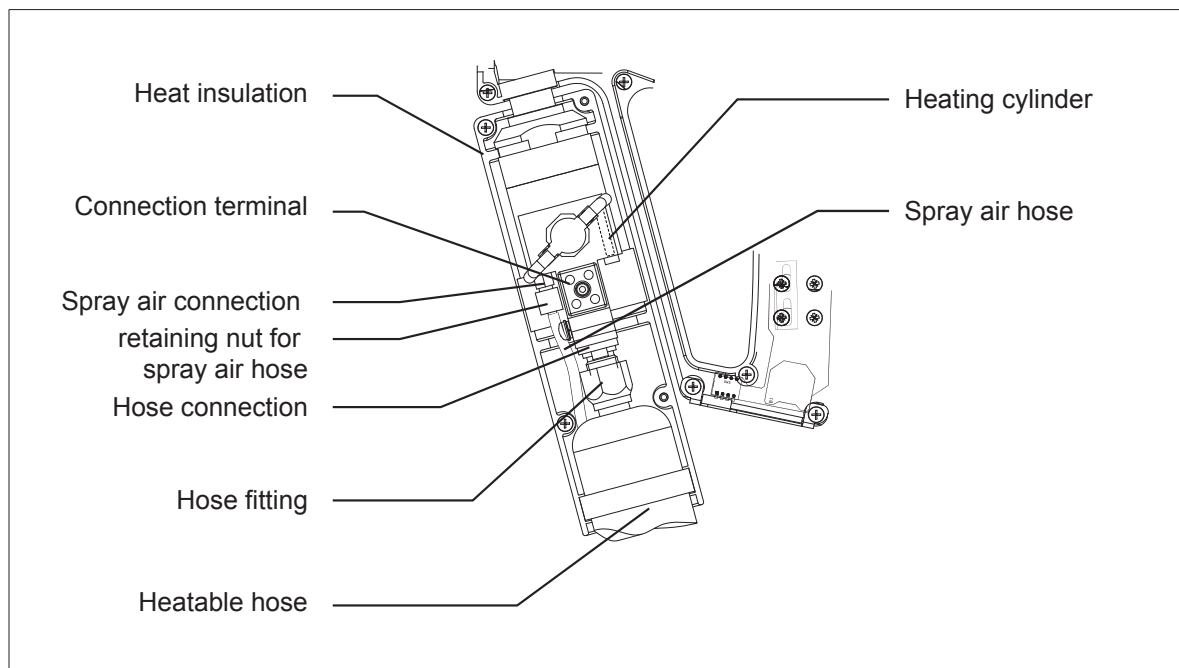

Figure 6.2/1: Hose connection in detail (using HS version as an example)

To dismantle the heatable hose, carry out the following work steps:

1. Heat up the heatable hose and the manual application unit to approx. 100 °C.
2. Turn off the pump of the tank system.
3. Activate the trigger on the manual application unit to release the system pressure.
4. **Disconnect the power plug from the tank system.**
5. **Only for HS version:**  
Remove the spray air hose from the spray air adapter kit of the tank system.



6. Release the fastening screws (4 pieces) of the heat insulation with the Phillips screwdriver. Remove the heat insulation consisting of 2 half-shells.
7. Release the electrical connections on the hose side as follows:
  - 2 conductors at connection terminal for heater (brown, blue)
  - 2 conductors at connection terminal for temperature sensor (2 x gray)
  - 1 conductor at screwed connection of protective conductor (green/yellow)
8. **Only for HS version:**  
Release the union nut of the spray air hose.
9. Release the nut of the heatable hose with open-end wrench size 17.  
Secure the connection to the heating cylinder with open-end wrench size 19.
10. Remove the hose from the heating cylinder. Keep on hand a rag or similar to be able to wipe up discharged hot melt material right away before it can drip into the housing of the manual application unit.  
For version HS, remove the spray air hose together with the heatable hose.



---

**Info**

Assembling the heatable hose occurs in reverse order. Tighten the hose fitting only by hand first. Permit the heatable hose and the manual application unit to heat up to approx. 100 °C before finally tightening the screws.

While tightening the hose fitting, make sure that the spray hose does not become twisted.

Refer to the circuit diagram in Chap. 2.2 when connecting the electrical lines.

When replacing the half shells, make sure that the flat portion of the arresting bars on the inside of the half shell are seated properly on the corresponding counter pieces at the heating cylinder.

---

## 6.3 Setting the preliminary/secondary air



### Danger of electric shock!

Disconnect the power plug from the tank system before carrying out the following work:  
Connecting and terminating electrical connections may only be implemented by competent electricians.

**Required tools:**  
1 Phillips screwdriver  
1 Allen wrench size 2.5

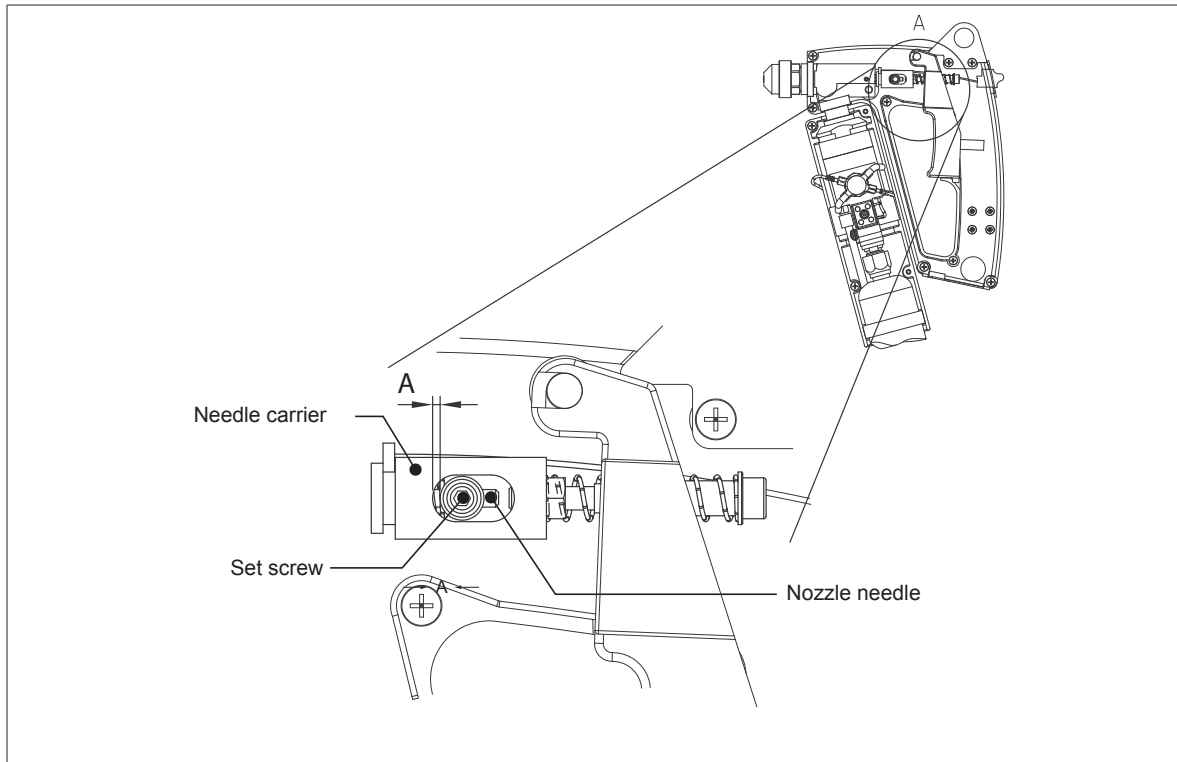

Figure 6.3/1: Setting the preliminary/secondary air

The preliminary/secondary air provides a drip-free spray pattern. It has been pre-set by the factory. These factory settings should only be changed in exceptional cases.

When converting to extrusion application (see Chap. 9.1.1), the preliminary/secondary air must be shut off. This simultaneously increases the needle stroke.

#### Setting preliminary/secondary air (Measure A)

Factory default	A = approx. 1.0 mm
For converting to extrusion application	A = 0.2 mm

To set the preliminary/secondary air, carry out the following work steps:

1. Dismantle the grip casing of the manual application unit (8 Phillip head screws).
2. Release the set screw with the Allen wrench size 2.5.
3. Twist the needle carrier to change the preliminary/secondary air to the desired measure.  
In doing so, make sure that the nozzle needle does not twist along.
4. Lightly retighten the set screw.
5. Assemble the grip casing.

## 6.4 Setting the switching code

**Required tools:** 1 Phillips screwdriver  
1 small slotted screwdriver

Triggering the pump in the basic unit is controlled by a transmitter in the hand unit. So that the basic unit only responds to the manual application units that are connected to this basic unit, the transmitter and basic unit must be set to the same switch code.

This switch code can be set using four small switches (“dip switches”) that can be accessed after removing a cover in the lower part of the hand grip.

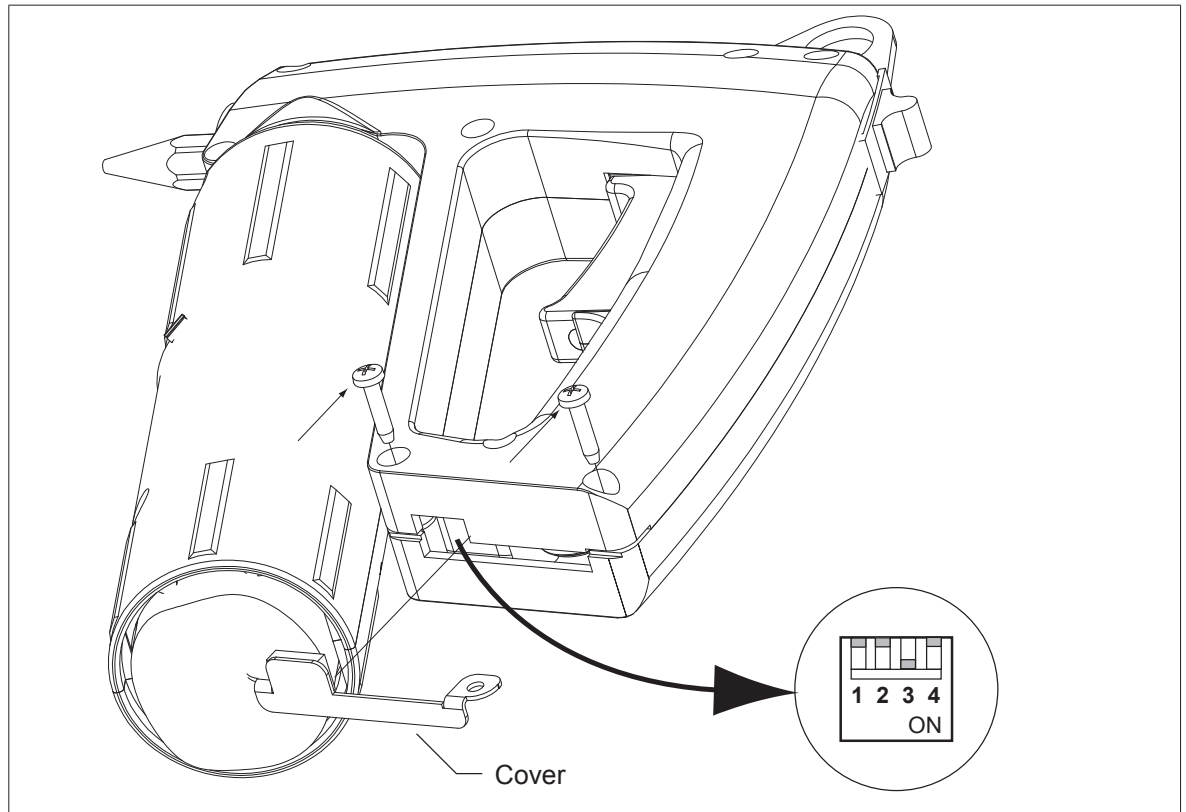
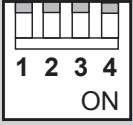
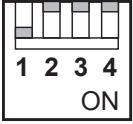
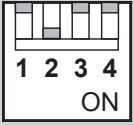
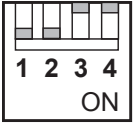
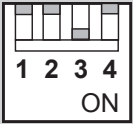
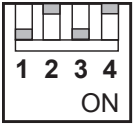
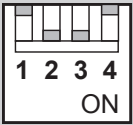
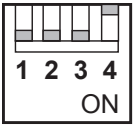
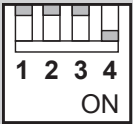
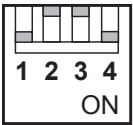
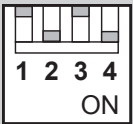

Figure 6.4/1: Position of switches for setting the switch code

To set the switch code, carry out the following work steps:

1. Release and remove the Phillips head screws as illustrated in Figure 6.4/1.
2. Remove the cover.
3. The switches in the left part of the grip underside are now accessible. Set the desired switch code (see table on the next page). Use the small screwdriver to activate the switches.
4. Reinsert the cover.
5. Screw both Phillips head screws back in.

# Set-up / Retrofit

Switch code	Switch setting
0	 <p>1 2 3 4 ON</p>
1	 <p>1 2 3 4 ON</p>
2	 <p>1 2 3 4 ON</p>
3	 <p>1 2 3 4 ON</p>
4	 <p>1 2 3 4 ON</p>
5	 <p>1 2 3 4 ON</p>
6	 <p>1 2 3 4 ON</p>
7	 <p>1 2 3 4 ON</p>
8	 <p>1 2 3 4 ON</p>
9	 <p>1 2 3 4 ON</p>
10	 <p>1 2 3 4 ON</p>

## 7 Maintenance / Servicing

---



### Attention!

Maintenance works may only be implemented by competent personnel.

---

### 7.1 Maintenance intervals

Interval	Activity
Daily	<p>Check the manual application unit for leak tightness, the existence of all parts, and for firm seat of plug and screw connections.</p> <p>Remove hot melt material residues and other incrustations.</p>

### 7.2 Cleaning

---



### Attention!

Do not use any aggressive solvent or combustible cleaning agents to clean the manual application unit. Such substances can cause damage.

---

- Using a suitable tool (e.g. cloth, soft brush, wood spatula), mechanically remove hot melt material residue and other pollution.
  - If the nozzle is clogged, insert a needle or wire with matching diameter into the (heated) nozzle hole.
  - The manual application unit can also be cleaned by rinsing it with a suitable cleaning agent (see operating instructions of the basic unit).
- 



### Info

Have your hot melt manufacturer advise you about suitable cleaning agents. Observe the processing spec sheet and the safety data sheet of the hot melt adhesive.

---

### 7.3 Replacing the transmitter battery

**Required tools:** 1 Phillips screwdriver

**Required material:** 1 lithium battery 3V, type CR 2032

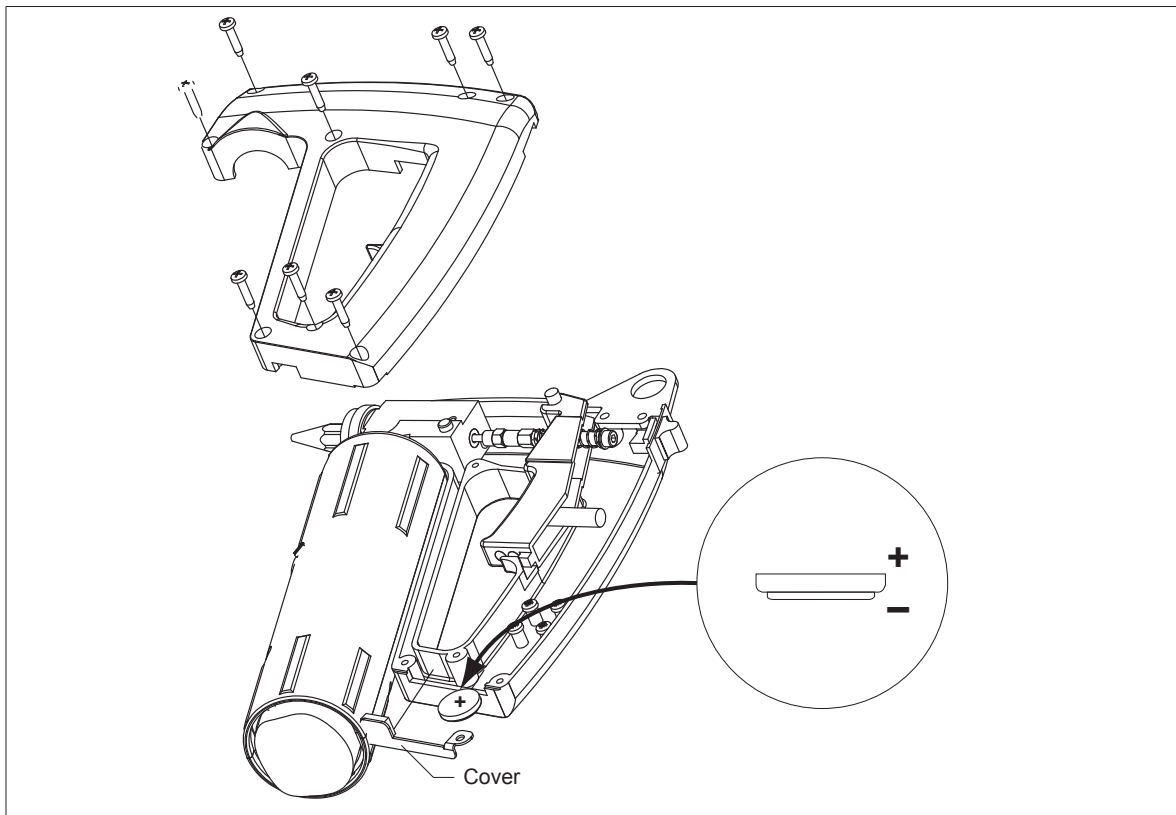

Figure 7.3/1: Replacing the transmitter battery

To replace the transmitter battery, carry out the following work steps:

1. Release and remove the Phillips head screws as illustrated in Figure 7.3/1.
2. Remove the cover.
3. Pull the battery out of the end of the grip as illustrated.
4. Slide the new battery into the end of the grip.  
Please observe correct polarity of the battery (see Figure 7.3/1)!
5. Reinsert the cover.
6. Screw both Phillips head screws back in.
7. Dispose of the drained battery in an environment-friendly manner. Comply with the local laws and regulations.



Li

## 8 What happens if...

For occurring malfunctions and faults, first check

- the power supply and all electrical connections
- whether the main switch and the pump switched have been turned on
- whether the temperature values for the utilized hot melt adhesive have been set correctly

If defects occur, a protective circuit protects the manual application unit in any case from being heated to temperatures exceeding 260 °C.



### Attention!

**Never bypass** the overtemperature fuse in the manual application unit!

Fault	Possible cause	Remedy
Temperature fluctuates strongly or application unit does not heat	Defective temperature sensor	Replace
	Defective control unit	Replace
	Overtemperature fuse was triggered	Let manual application unit cool off. Determine cause.
	Heating cartridge defective	Replace
	No power supply from the tank system	Check the tank system and/or the heatable hose.
No hot melt material is discharged.	Depleted transmitter battery	Check whether the tank system pumps will start when the trigger is activated. If not: <ul style="list-style-type: none"> <li>• Check battery for correct position. If correct:</li> <li>• Replace transmitter battery (see Chap. 7.3)</li> </ul>
No or insufficient hot melt material is discharged	Hot melt tank is empty	Fill up
	Hot melt material viscosity is too high	Observe processing notes of hot melt material manufacturer
	Clogged nozzle	Clean (see also Chap. 7.2)
	Hot melt material transport from tank system defective	Check the tank system and/or the heatable hose.

What happens if...



## 9 Accessories

### 9.1 Adapter for extrusion application (for HS version only)

By installing this adapter (order no. FDH 0423) extrusion application is possible with the Spray version (HS) manual application unit as well.

The adapter is designed for nozzles with UNF 3/8" threads.

#### 9.1.1 Converting to extrusion application



#### Wear safety gloves!

Danger of burns due to hot metal parts and due to discharged hot melt material. To avoid burning yourself while assembling the adapter, always wear heat protection gloves.

**Required tools:** 1 open-end wrench size 13  
1 open-end wrench size 22

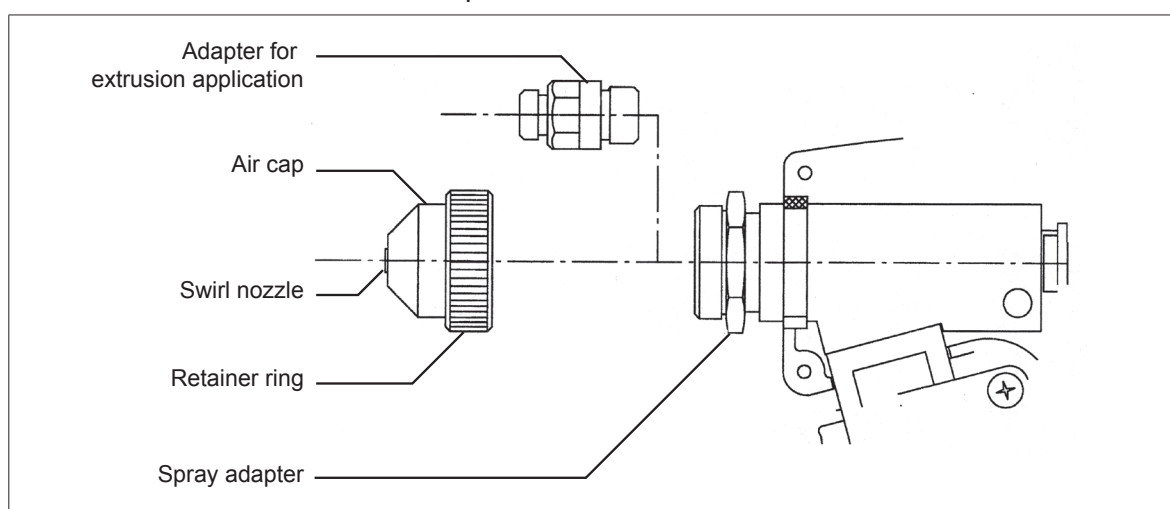

Figure 9.1.1/1: Assembling the adapter for extrusion application

To assemble the adapter, carry out the following work steps:

1. Heat up the manual application unit to approx. 100 °C.
2. Turn off the pump of the tank system.
3. Activate the trigger on the manual application unit to release the system pressure.
4. **Disconnect the power plug from the tank system.**
5. Remove the spray air hose from the spray air adapter kit of the tank system.
6. Secure the spray adapter with the open-end wrench size 22.
7. Remove the air cap.
8. Unscrew the swirl nozzle.
9. Screw on the adapter for extrusion application by hand first. Let the adapter thoroughly heat for about 2 minutes.
10. Tighten the adapter **without using force**.
11. Screw on the desired nozzle to the adapter by hand first. Let the nozzle also thoroughly heat for about 2 minutes.
12. Tighten the nozzle **without using force**.
13. Turn off the preliminary/secondary air (see Chap. 6.3).
14. Set the spray air pressure on the spray air adapter kit of the tank system to "0."



## 10 Repairs

Repairs other than those described in these operating instructions may only be implemented by competent persons commissioned by the manufacturer or otherwise competent persons under utilization of original BÜHNEN spare parts.

## 11 Warranty

The unit was developed and manufactured according to the latest state of technology. The first purchaser receives warranty on function, material, and processing according to statutory regulations. Normal wear and tear is excepted.

The warranty is void if improper handling, use of violence, repairs by third parties and the installation of spare parts other than the original has been determined.

The warranty extends to servicing or replacing according to our choice. Warranty beyond our scope of delivery is excluded, as we do not have any influence on the competent and expert use of the unit.

Please observe our terms and conditions!

## 12 Disposal



Take the unit, packaging, and accessories to an environmentally friendly recycling center (in accordance with Directive 2002/96/EG of the European Parliament and the Council of January 27, 2003).



BÜHNEN GmbH & Co. KG  
Hinterm Sielhof 25  
28277 Bremen • Germany  
Phone: +49 (0) 421 51 20 - 125  
Fax: +49 (0) 421 51 20 - 260  
kleben@buehnen.de  
www.buehnen.de

## Declaration of Conformity

Hot melt adhesive application system

**HB 5010**





## Declaration of Conformity

We, **Bühnen GmbH & Co KG.**  
**D-28277 Bremen**

declare in sole responsibility that the product

**Hot Melt Adhesive Tank System HB 5010**

to which this declaration refers, conforms to the following standards or normative documents in its delivery state:

**Geräte- und Produktsicherheitsgesetz (GPSG)**

**Elektro- und Elektronikgerätegesetz (ElektroG)**

**DIN EN ISO 12100-1, -2**

**DIN EN 60204-1**

**DIN EN 61000-4-2/3/4/6/8**

in accordance with the provisions of the directives

2001/95/EG

2004/108/EG

2006/42/EG

2011/65/EG

Bremen, May 2014

A handwritten signature in black ink, appearing to read 'H. Kruse'.

Hermann Kruse  
Technical Director  
Documentation Representative

A handwritten signature in black ink, appearing to read 'H. Pünjer'.

Hanno Pünjer  
Managing Director

BÜHNEN GmbH & Co. KG  
Hinterm Sielhof 25  
28277 Bremen • Germany  
Phone: +49 (0) 421 51 20 - 125  
Fax: +49 (0) 421 51 20 - 260  
kleben@buehnen.de  
www.buehnen.de

**BÜHNEN**  
KLEBESYSTEME



Translation of the original Operating Manual

Hot melt adhesive tank system

**HB 5010**

## Table of contents

<b>1</b>	<b>HB 5010 Tank System (basic unit)</b> .....	<b>3</b>
<b>2</b>	<b>Manual application unit</b> .....	<b>12</b>
2.1	Extrusion version (HR) .....	12
2.2	Spray Version (HS) .....	14
<b>3</b>	<b>Wiring diagram</b> .....	<b>17</b>

**1 HB 5010 Tank System (basic unit)**

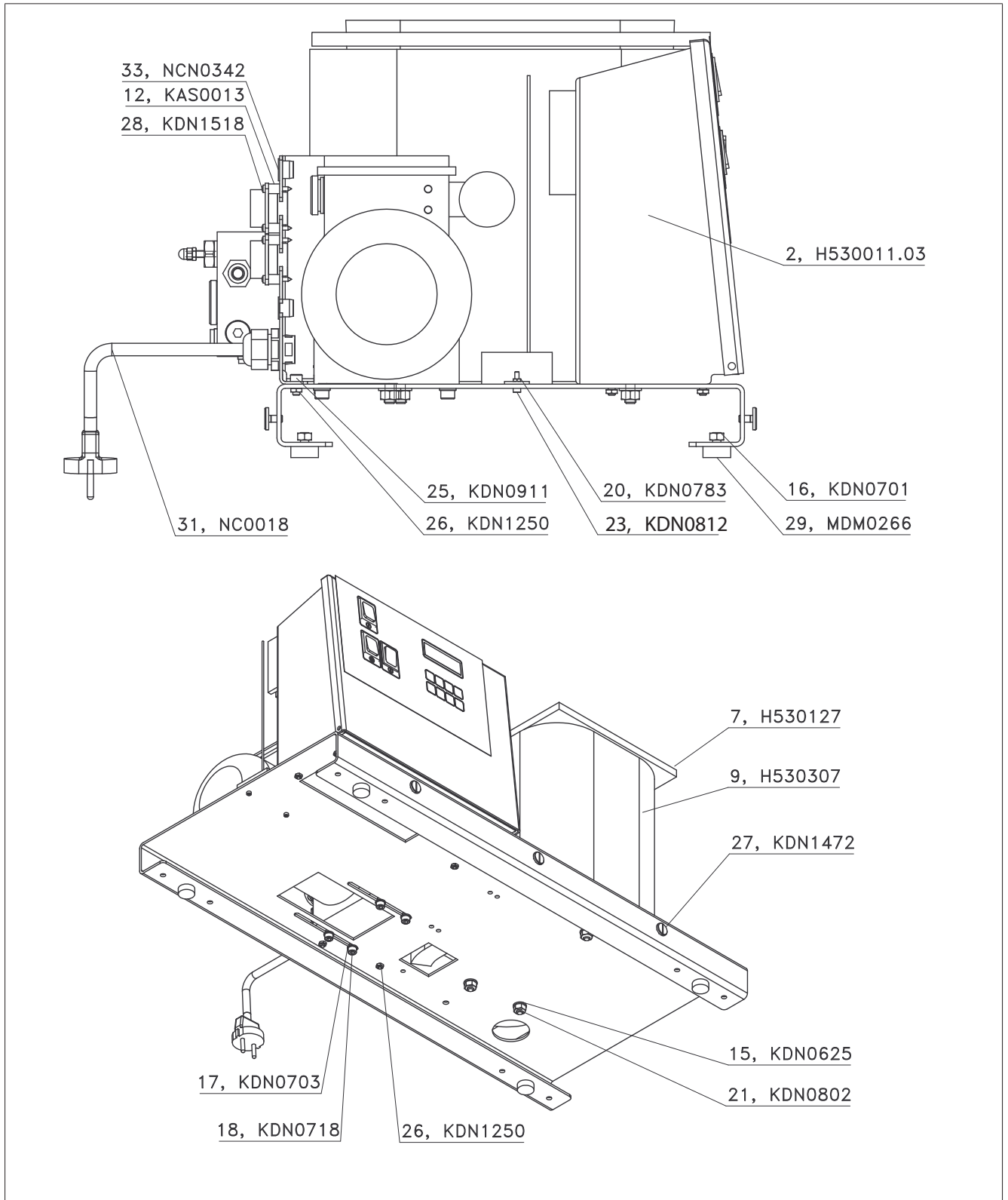

Figure 1/1: Spare parts for basic unit, Part 1

# Spare parts list

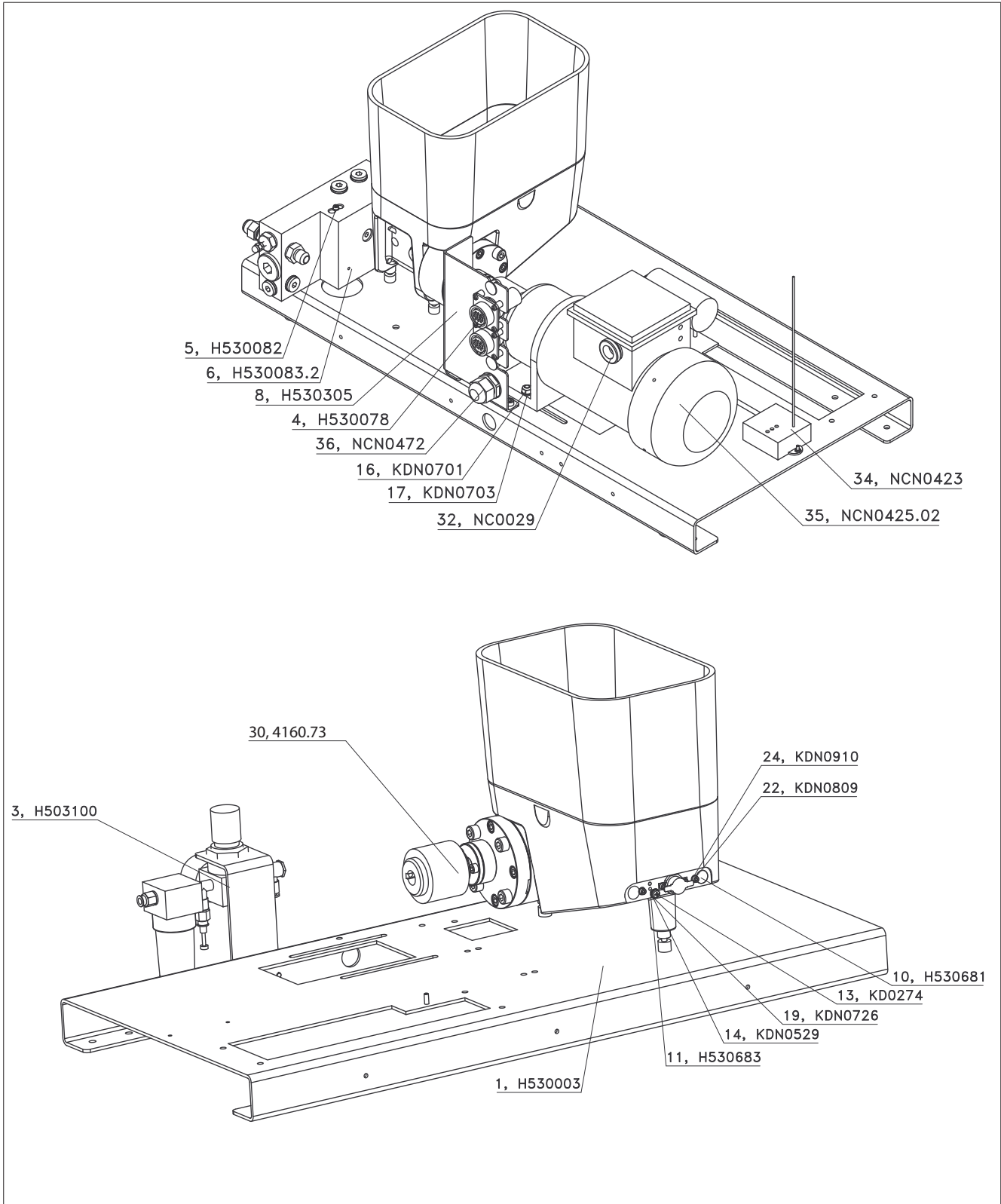

Figure 1/2: Spare parts for basic unit, Part 2

## Spare parts for basic unit

Item	Order No.	Quantity	Designation
1	H530303	1	Console
2	H530011.03	1	Switch cabinet, complete
3	H503100	1	Spray-air adapter kit
4	H530078	1	Outlet with connection cable
5	H530082	1	Connection cable pump heater
6	H530083.2	1	Temperature sensor pump
7	H530127	1	Tank seal
8	H530305	1	Holding plate
9	H530307	1	Insulation
10	H530681	1	Connection cable tank heater
11	H530683	1	Temperature sensor tank
12	KAS0013	8	Spacing bush
13	KD0274	1	Screw
14	KDN0529	1	Lock washer
15	KDN0625	3	U washer
16	KDN0701	8	Nut
17	KDN0703	4	Washer
18	KDN0718	4	Screw
19	KDN0726	1	Washer
20	KDN0783	2	Nut
21	KDN0802	3	Nut
22	KDN0809	2	Screw
23	KDN0812	2	Screw
24	KDN0910	2	U washer
25	KDN0911	6	Cheese head screw
26	KDN1250	6	Hexagon nut
27	KDN1472	6	Slotted pan head screw
28	KDN1518	8	Tapping screw Din7981
29	MDM0266	4	Screwable housing foot
30	4160.73	1	BoWex coupling M24.14-12
31	NC0018	1	Power cable complete
32	NC0029	1	Cable support sleeve
33	NCN0342	2	Blind plug
34	NCN0423	1	Radio receiver
35	NCN0425.02	1	Electric motor with capacitor
36	NCN0472	1	Screwed connection

## Spare parts list

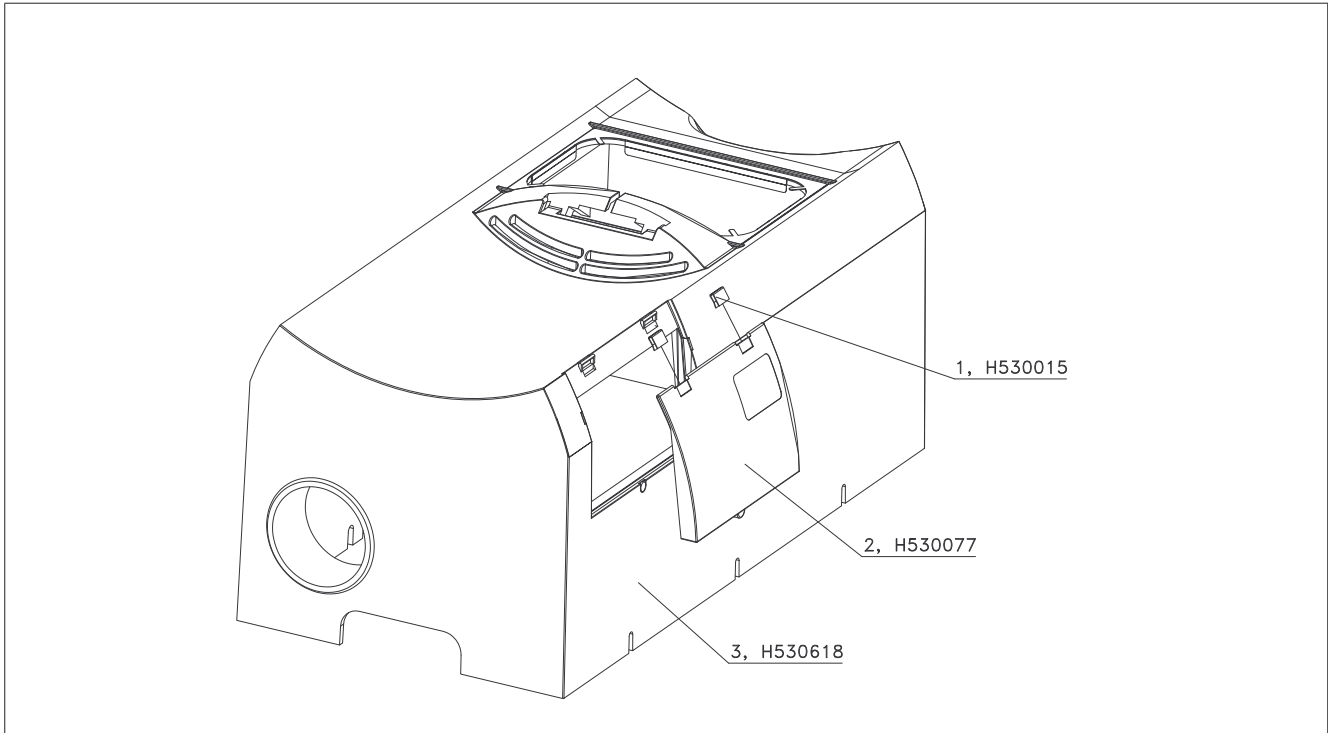

Figure 1/3: Spare parts for basic unit, housing with attachments

### Spare parts for basic unit (housing with attachments)

Item	Order No.	Quantity	Designation
1	H530015	2	Clamp
2	H530077	1	Protective lid with magnet
3	H530618	1	Housing complete

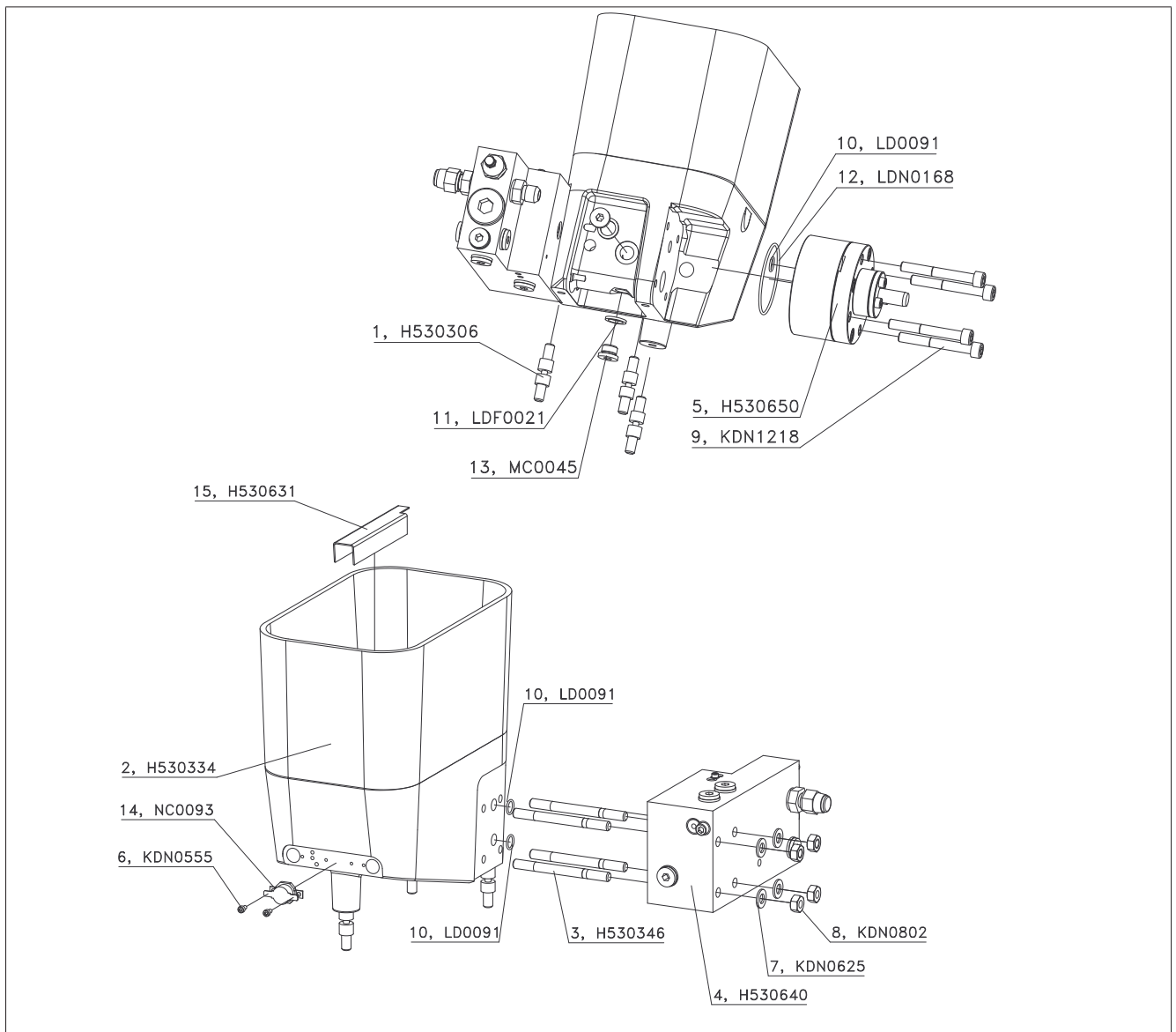

Figure 1/4: Spare parts for basic unit, hot melt tank

### Spare parts for basic unit (hot melt tank)

Item	Order No.	Quantity	Designation
1	H530306	3	Stud bolt
2	H530334	1	Hot melt tank
3	H530346	4	Stud bolt
4	H530640	1	Connection block complete
5	H530650	1	Gear wheel pump complete
6	KDN0555	2	Screw
7	KDN0625	4	U washer
8	KDN0802	4	Nut
9	KDN1218	4	Screw
10	LD0091	3	O-ring
11	LDF0021	2	Gasket ring 1/4 Alu
12	LDN0168	1	O-ring
13	MC0045	2	Blind plug G1/4
14	NC0093	1	Temperature controller
15	H530631	1	Inlet sieve D = 4 mm

## Spare parts list

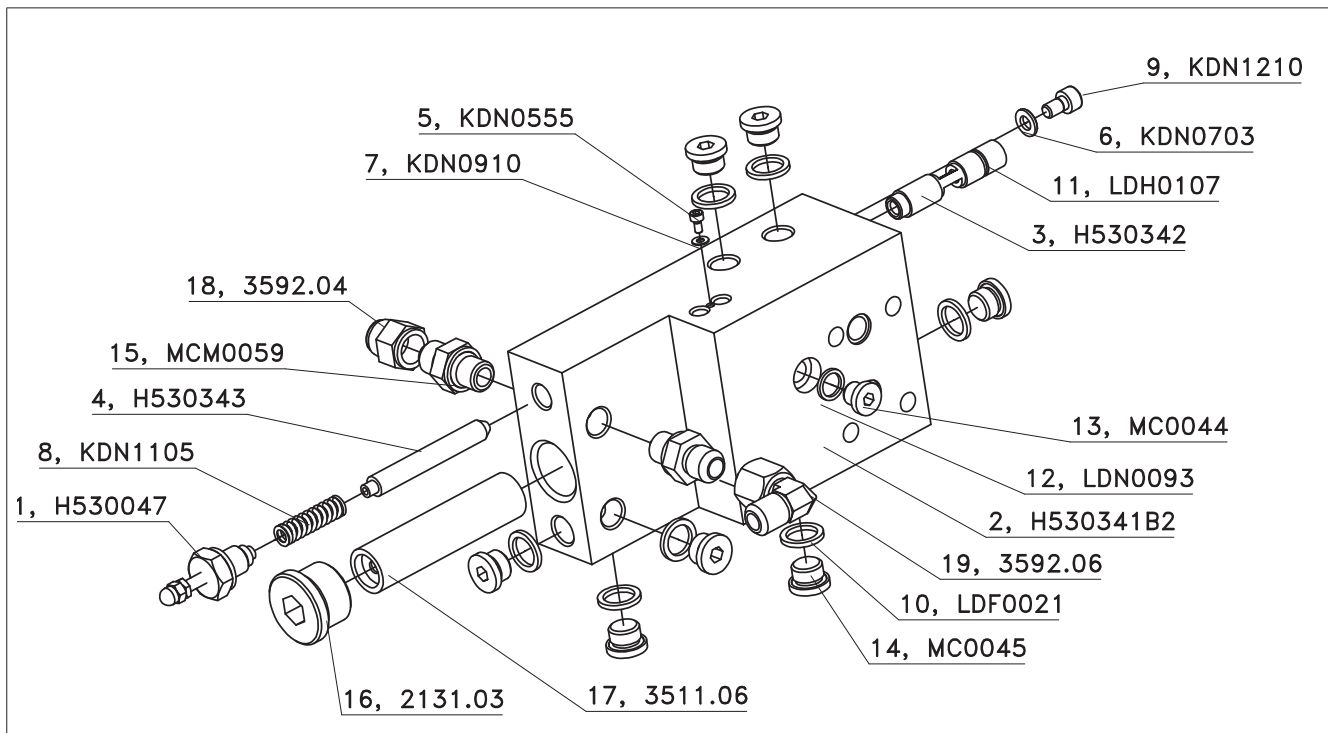

Figure 1/5: Spare parts for basic unit, connection block

### Spare parts for basic unit (connection block)

Item	Order No.	Quantity	Designation
1	H530047	1	Bypass movement
2	H530341B2	1	Connection block
3	H530342	1	Base of valve stem
4	H530343	1	Valve cone
5	KDN0555	1	Screw DIN 912
6	KDN0703	1	Washer
7	KDN0910	1	U washer
8	KDN1105	1	Compression spring
9	KDN1210	1	Screw
10	LDF0021	8	Gasket ring 1/4" Alu
11	LDH0107	1	O-ring
12	LDN0093	1	Gasket ring
13	MC0044	1	Blind plug G1/8
14	MC0045	8	Blind plug G1/4
15	MCM0059	2	Hose connection
16	2131.03	1	Locking screw with viton seal
17	3511.06	1	Screen filter
18	3592.04	1	Locking cap
19	3592.06	1	Hose connection Sa8



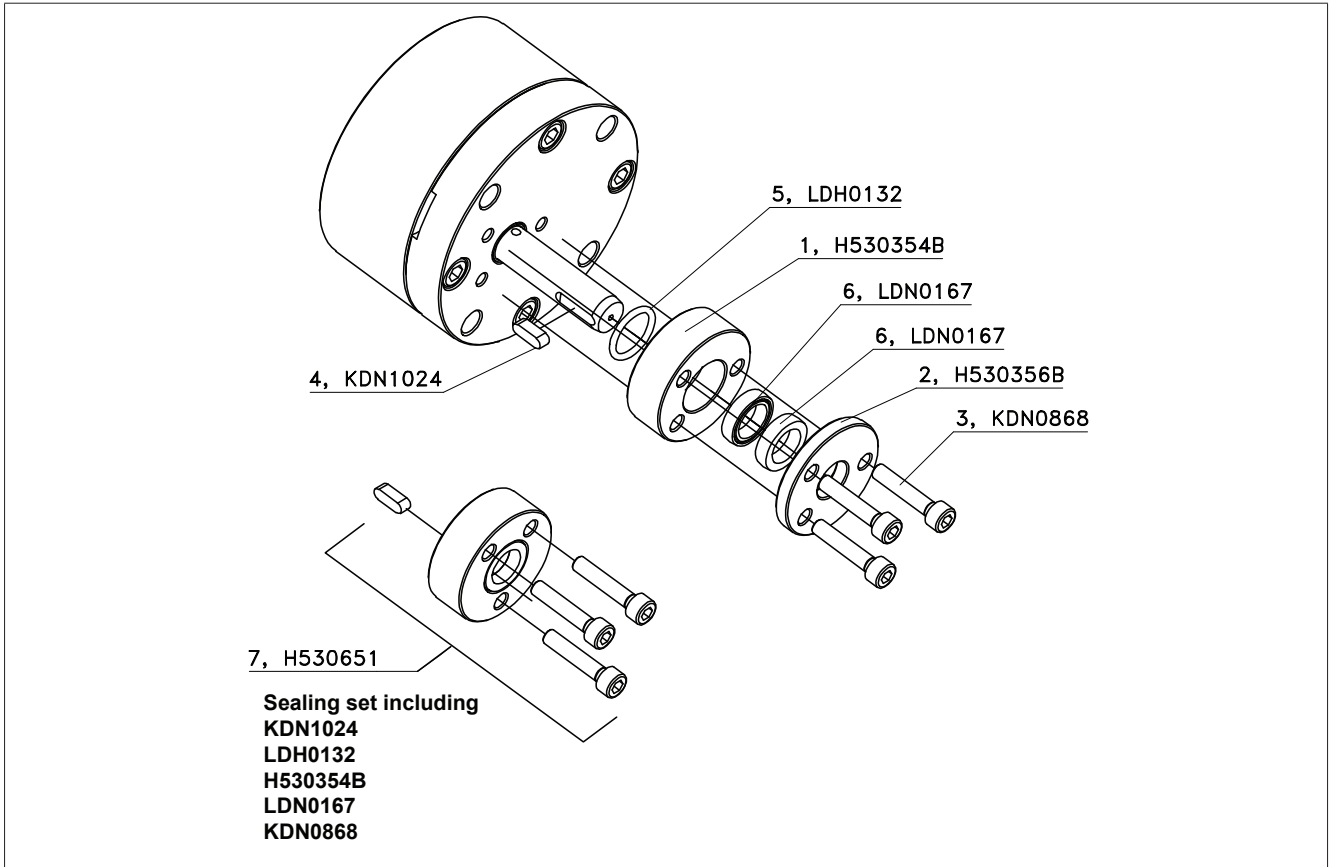

Figure 1/6: Spare parts for basic unit, gear wheel pump

**Spare parts for basic unit (gear wheel pump)**

Item	Order No.	Quantity	Designation
1	H530354B	1	Sealing flange
2	H530356B	1	Cover
3	KDN0868	3	Screw
4	KDN1024	1	Adjustment spring
5	LDH0132	1	O-ring
6	LDN0167	2	Brass lip seal
7	H530651	1	Sealing set

## Spare parts list

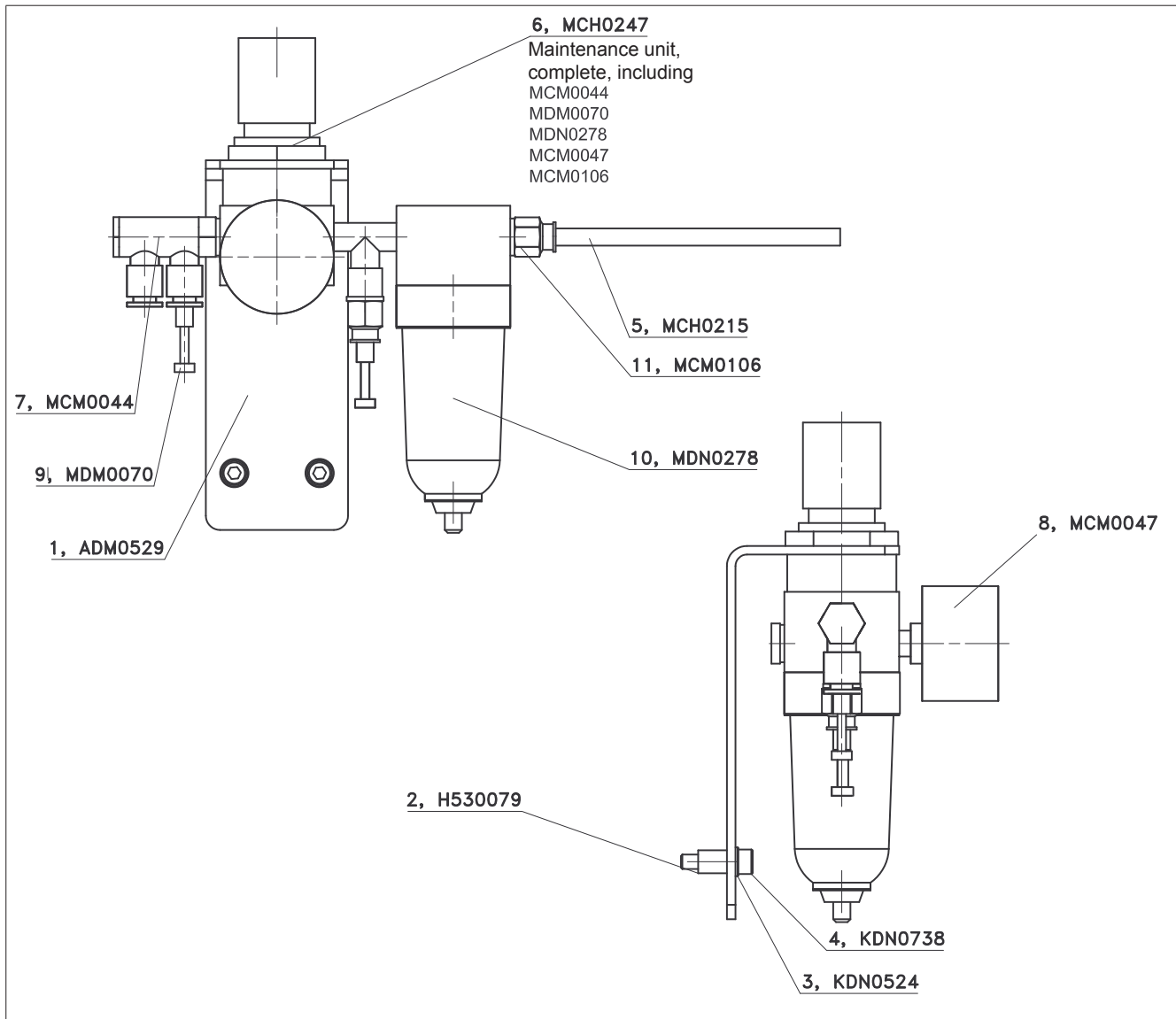

Figure 1/7: Spare parts for basic unit, spray-air adapter kit

### Spare parts for basic unit (spray-air adapter kit)

Item	Order No.	Quantity	Designation
1	ADM0529	1	Angle bracket
2	H530079	2	Spacing disc
3	KDN0524	2	Washer
4	KDN0738	2	Screw
5	MCH0215	1	PUR air hose Nw4
6	MCH0247	1	Maintenance unit HB 6000
7	MCM0044	1	Multiple distributor
8	MCM0047	1	Pressure gauge
9	MDM0070	1	Stopper

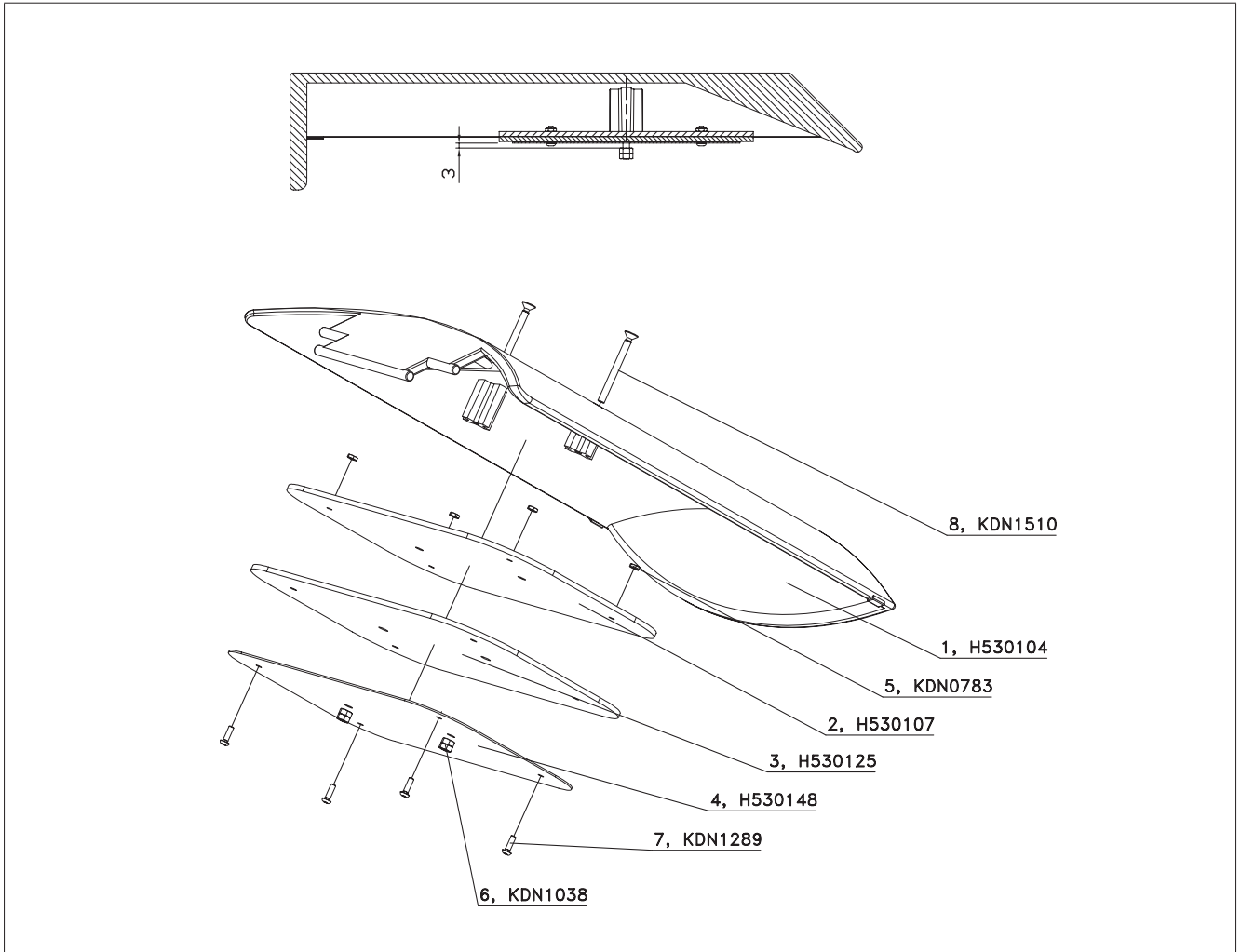

Figure 1/8: Spare parts for basic unit, housing and tank lid

### Spare parts for basic unit (housing and tank lid)

Item	Order No.	Quantity	Designation
1	H530104	1	Housing cover
2	H530107	1	Tank lid
3	H530125	1	Sealing plate
4	H530148	1	Sealing plate
5	KDN0783	4	Nut
6	KDN1038	4	Hexagon nut
7	KDN1289	4	Screw
8	KDN1510	2	Recessed countersunk flat head screw

**2 Manual application unit**  
**2.1 Extrusion version (HR)**

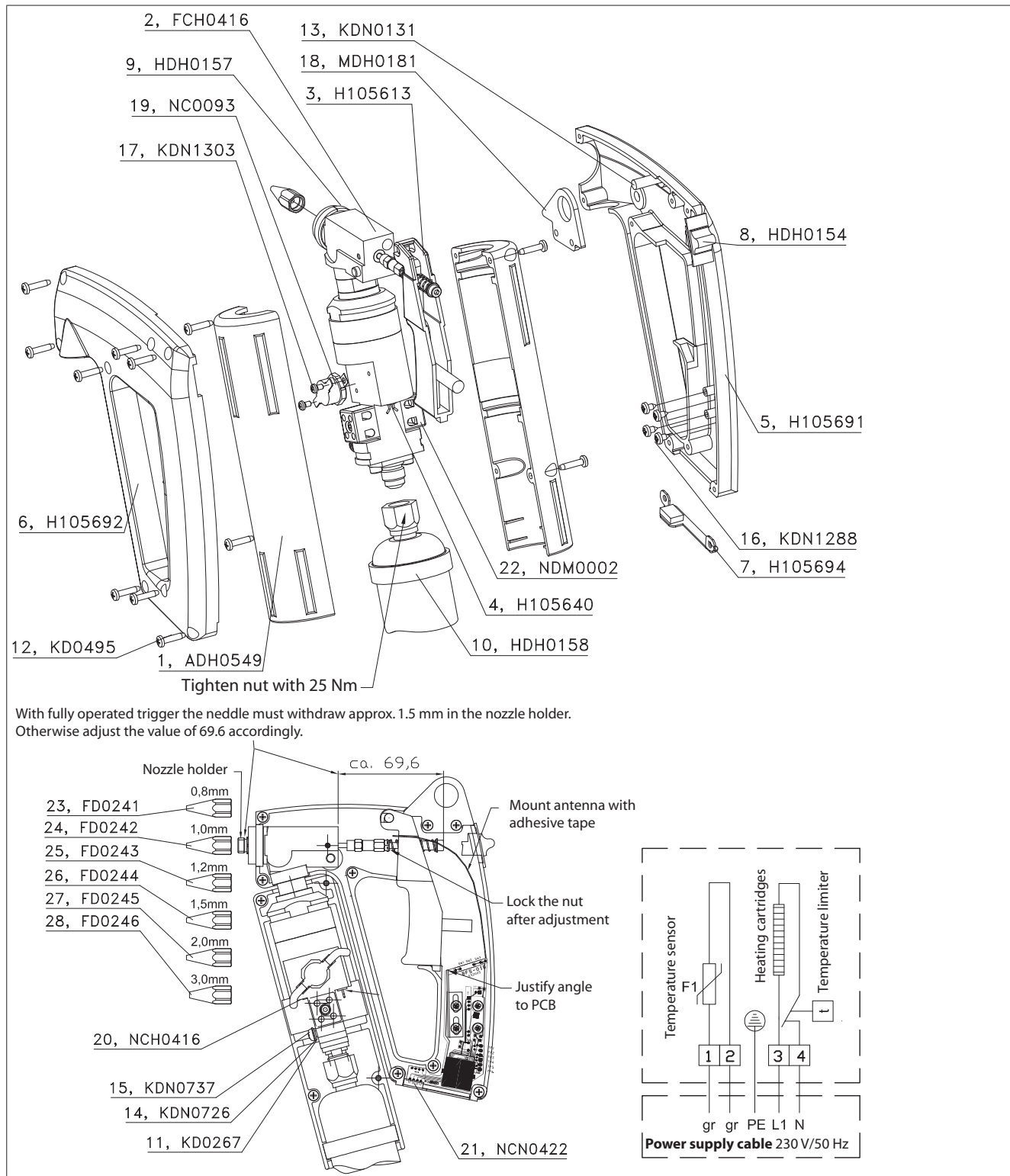

Figure 2.1/1: Spare parts, manual application unit, Extrusion Version

**Spare parts, manual application unit (Extrusion Version)**

Item	Order No.	Quantity	Designation
1	ADH0549	2	Heat insulation half shell
2	FCH0416	1	Nozzle head with heating cylinder
3	H105613	1	Trigger with magnet
4	H105640	1	Heating cartridge with cable
5	H105691	1	Grip casing right
6	H105692	1	Grip casing left
7	H105694	1	Cover with foamed material
8	HDH0154	1	Lock slider
9	HDH0157	1	Spacer ring
10	HDH0158	1	Support ring
11	KD0267	1	Spring ring
12	KD0495	12	Plastite screw
13	KDN0131	1	Parallel pin
14	KDN0726	1	Washer
15	KDN0737	1	Schraube
16	KDN1288	4	Blechschraube DIN 7981
17	KDN1303	2	Screw
18	MDH0181	1	Plate
19	NC0093	1	Temperature controller
20	NCH0416	1	Temperature sensor
21	NCN0422	1	Radio transmitter for hand-operated pistol
22	NDM0002	2	Terminal block
23	FD0241	1	Nozzle, long 0,8 mm
24	FD0242	1	Nozzle, long 1,0 mm
25	FD0243	1	Nozzle, long 1,2 mm
26	FD0244	1	Nozzle, long 1,5 mm
27	FD0245	1	Nozzle, long 2,0 mm
28	FD0246	1	Nozzle, long 3,0 mm

## 2.2 Spray Version (HS)

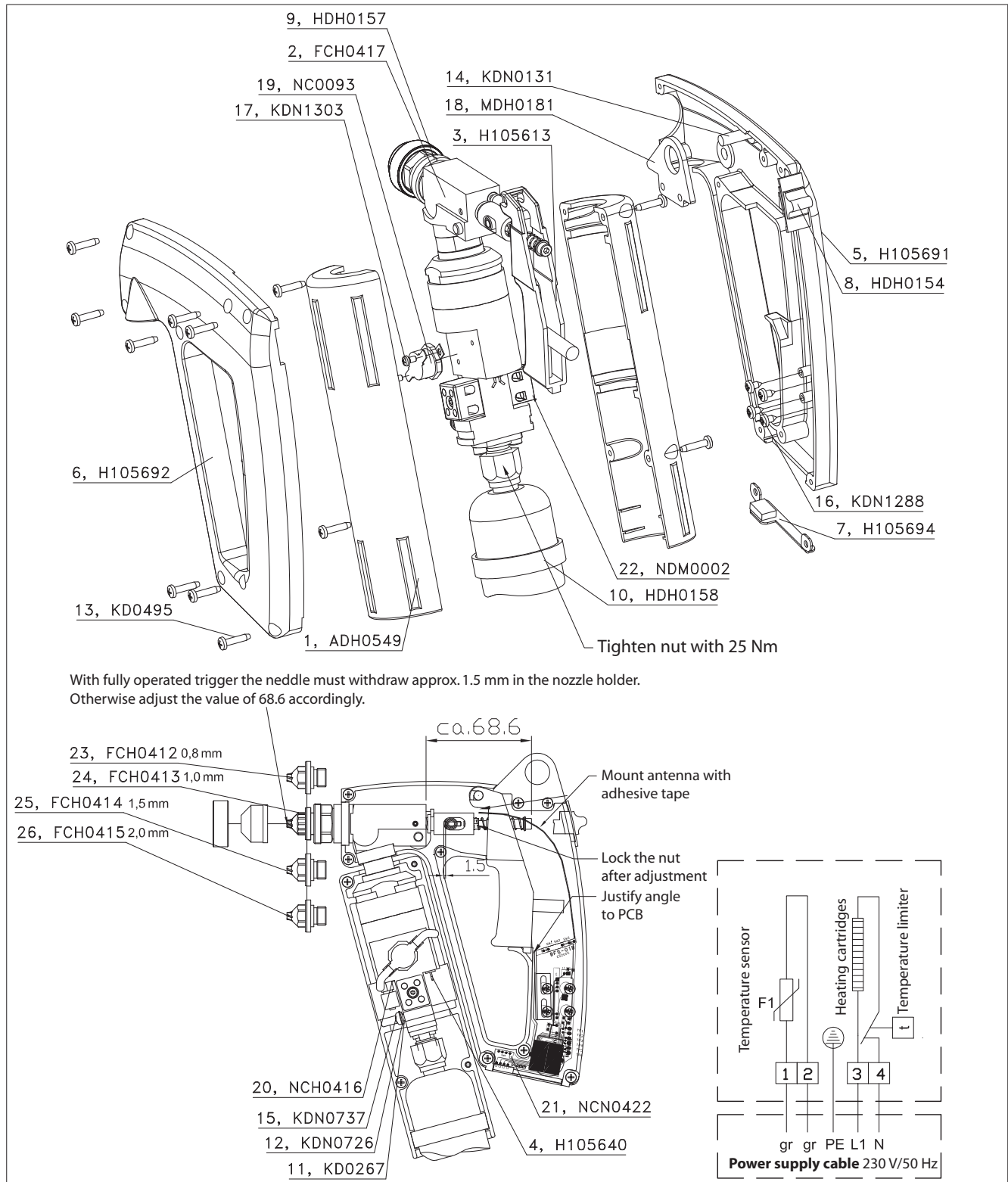

Figure 2.2/1: Spare parts, manual application unit, Spray Version

**Spare parts, manual application unit (Spray Version)**

Pos.	Bestell-Nr.	Anzahl	Bezeichnung
1	ADH0549	2	Heat insulation half shell
2	FCH0417	1	Nozzle head with heating cylinder
3	H105613	1	Trigger with magnet
4	H105640	1	Heating cartridge with cable
5	H105691	1	Grip casing right
6	H105692	1	Grip casing left
7	H105694	1	Cover with foamed material
8	HDH0154	1	Lock slider
9	HDH0157	1	Spacer ring
10	HDH0158	1	Support ring
11	KD0267	1	Spring ring
12	KDN0726	1	Washer
13	KD0495	12	Plastite screw
14	KDN0131	1	Parallel pin
15	KDN0737	1	Schraube
16	KDN1288	4	Blechschaube DIN 7981
17	KDN1303	2	Screw
18	MDH0181	1	Plate
19	NC0093	1	Temperature controller
20	NCH0416	1	Temperature sensor
21	NCN0422	1	Radio transmitter for hand-operated pistol
22	NDM0002	2	Terminal block
23	FCH0412	1	Spraying nozzle set
24	FCH0413	1	Spraying nozzle set
25	FCH0414	1	Spraying nozzle set
26	FCH0415	1	Spraying nozzle set





### 3 Wiring diagram

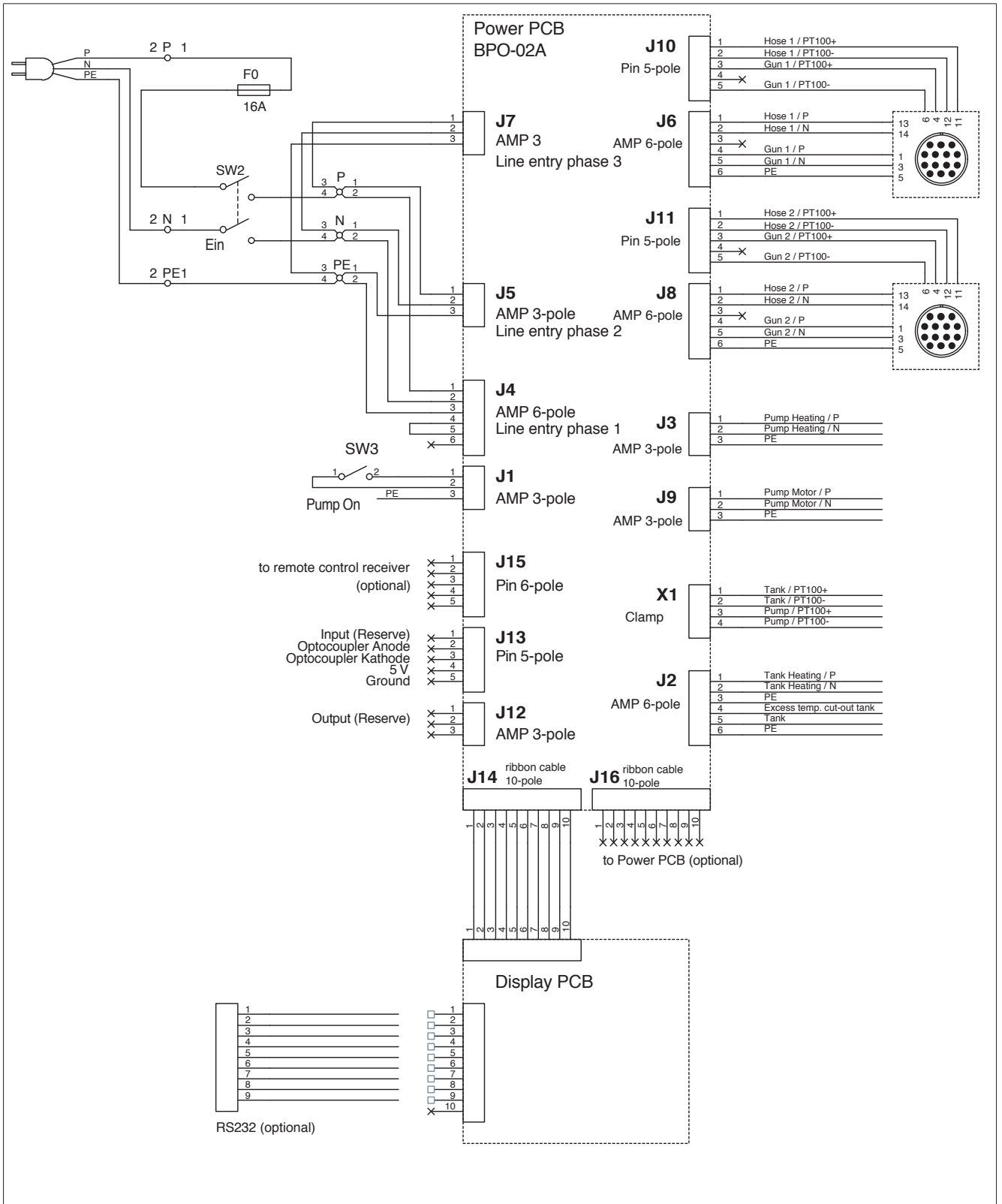

Figure 3/1: Wiring diagram

BÜHNEN GmbH & Co. KG  
Hinterm Sielhof 25  
28277 Bremen • Germany  
Phone: +49 (0) 421 51 20 - 125  
Fax: +49 (0) 421 51 20 - 260  
kleben@buehnen.de  
www.buehnen.de

**BÜHNEN**  
KLEBESYSTEME



Maintenance plan to the

Hot melt adhesive tank system

**HB 5010**



<b>1</b>	<b>Specific security advice .....</b>	<b>5</b>
<b>2</b>	<b>Regular maintenance .....</b>	<b>5</b>
2.1	Daily maintenance.....	5
2.2	Weekly maintenance .....	5
2.3	Every 500 hours .....	6
2.4	Every 3 months .....	6
2.5	Every 3 years .....	6
<b>3</b>	<b>Description of maintenance work.....</b>	<b>7</b>
3.1	Releasing system pressure .....	7
3.2	Cleaning/Draining the tank.....	7
3.3	Check/replacement of filter cartridge .....	8



## 1 Specific security advice



### Danger!

Maintenance work may only be carried out by competent personnel. Disregarding this note can cause damage to the tank system and/or injuries to the personnel.



### Danger of burns

Due to hot metal parts, hot melt material, and hot melt material vapours. Therefore, always wear heat protection gloves during the following described work.

## 2 Regular maintenance

The maintenance work described in the following must always be carried out carefully and on schedule. You thus guarantee the safe and reliable operation of the HB 5010 tank system.

### 2.1 Daily maintenance

Activity	to component:			
	Basic unit	Heated hose	Manual application unit	Spray air adapter kit
Remove hot melt material residues and other impurities from the tank system	✓	✓	✓	
Each time before you fill the tank, check the tank for impurities and foreign objects (remove immediately as necessary).	✓			
Visually inspect the tank system for signs of outer damage and leaks.	✓	✓	✓	✓

### 2.2 Weekly maintenance

Activity	to component:			
	Basic unit	Heated hose	Manual application unit	Spray air adapter kit
Check all mechanical and electrical connections for tight fit.	✓	✓	✓	✓
For tank systems with spray-air adapter kits: Drain the maintenance unit. Replace dirty filters as needed.				✓

## Regular maintenance

### 2.3 Every 500 hours

Activity	to component:			
	Basic unit	Heated hose	Manual application unit	Spray air adapter kit
Clean the interior of the tank. To do so, completely drain the tank.	✓			
Check the gear wheel pump for hot melt material discharge.	✓			

### 2.4 Every 3 months

Activity	to component:			
	Basic unit	Heated hose	Manual application unit	Spray air adapter kit
Check the filter cartridge in the gear wheel pump for contamination. Replace the filter cartridge as necessary. To do so, release the system pressure.	✓			

### 2.5 Every 3 years

Activity	to component:			
	Basic unit	Heated hose	Manual application unit	Spray air adapter kit
Replace the back-up battery of the real-time clock in the control unit (see Part 2 (basic unit), Chap. 8.3).	✓			
Replace the transmitter battery in the applicator (see Part 4 (Applicators), Chap. 7.3).			✓	



### 3 Description of maintenance work

For your own safety during all maintenance work, always observe the security advice in Chap. 1.

#### 3.1 Releasing system pressure

The system pressure must be released before some of the maintenance and repair work.

To do so, proceed as follows:

1. Make sure that the tank system has been thoroughly heated.
2. Turn off the pump.
3. Place a collection basin under the nozzle of the applicator.
4. Activate the trigger of the applicator until the hot melt material no longer discharges.

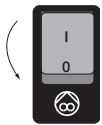

#### 3.2 Cleaning/Draining the tank

**Required tools:**

- 1 wooden scraper

To clean/drain the tank, carry out the following work steps:

1. Heat up the tank until the contained hot melt adhesive is completely melted.
2. Hang a wooden scraper (or other piece of wood) in the interior of the tank so that it dips about halfway into the hot melt adhesive.
3. Lay a strip of wood (or something similar) across the tank. Attach the wooden scraper (using a piece of wire, for example) to this strip of wood.
4. Let the tank cool down until the hot melt adhesive is completely hardened.
5. Now briefly reheat the tank until the edges of the hot melt adhesive start to melt.
6. You can now lift the entire block of hot melt adhesive with the melted-in wooden scraper out of the tank.

Usually all impurities are removed from the tank along with the block of hot melt adhesive. If impurities remain on the walls of the tank, you can carefully remove them using a wooden scraper.



#### **Attention!**

**Never** use metal objects or similarly hard objects to clean the tank.

The interior of the tank is provided with an anti-stick coating, which could be damaged.

### 3.3 Check/replacement of filter cartridge

**Required tools:**

- 1 Allen key 12mm

**Spare part:**

- 1 filter cartridge  
(Order No. 3511.06)

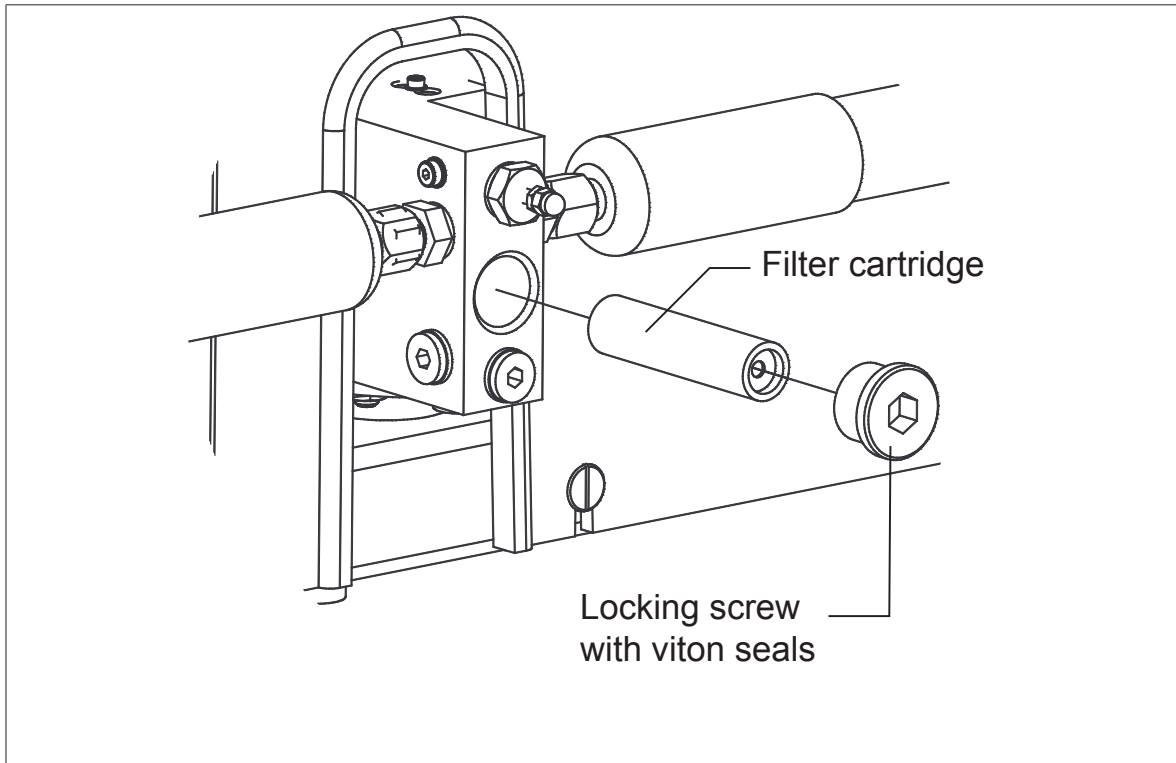

Figure 3.3/1: Position of filter cartridge

The filter cartridge for the hot melt adhesive is located in the connection block that can be accessed from the rear of the basic unit.

Figure 3.3/1 shows the position of the filter cartridge in the connection block.

To inspect/replace the filter cartridge, carry out the following work steps:

1. Heat up the tank system to approx. 100°C.
2. **Turn off the tank system and disconnect the mains plug.**
3. Release the locking screw with an Allen key (12mm).
4. The filter cartridge can now be removed and checked/replaced.

Reassembly is carried out in reverse order.